



FRANK'S
TOY SHOP

.750

K
4500

K4500

AIRFIX-72 SCALE

HAWKER DEMON

THE HAWKER DEMON

The Hawker Demon two-seat fighter was a logical development of the famous Hawker Hart bomber and was the first two-seat fighter to go into R.A.F. service since the First World War. The need for the Demon had become apparent during the 1930 Air Exercises when no R.A.F. fighter had sufficient performance to intercept the attacking Harts.

Late in 1930 two Harts were modified to incorporate an angled rear cockpit and after trials of these "Hart Fighters" a small production order was placed; these first fighters were tested during 1931 and 1932 and the experience gained resulted in the contract for a new aircraft, the Hawker Demon. The first Demon flew in February, 1933, and the new type was in squadron service the same year. During 1934 the Royal Australian Air Force and the Royal Air Force placed large orders for Demons which were delivered in the following two years.

At one stage eleven R.A.F. squadrons were equipped with the Demon which was finally replaced as an operational fighter in 1939. Several Demons continued to fly, however, mainly as target tugs, until the late years of the Second World War.

The Hawker Demon represented in this kit is the machine flown by the Squadron Leader of 604 Squadron of the Auxiliary Air Force from 1936.

Powered by a 485 h.p. Rolls-Royce Kestrel IIS engine, the Demon had a maximum speed of 182 m.p.h. Armament consisted of two fixed forward firing Vickers machine guns and one flexible Lewis gun. Wing span was 37 ft. 2 in. and overall length 29 ft. 7 in.

PLEASE OPEN CAREFULLY — INSTRUCTIONS OVERLEAF

AIRFIX

CONSTRUCTION KIT

1/72 SCALE MODEL CONSTRUCTION KIT

HAWKER DEMON

INSTRUCTIONS

PAINT ALL DETAILS AND LET DRY BEFORE ASSEMBLING (SEE SECTION 4)
N.B. FOR PAINTING USE "AIRFIX" PAINTS, FOR FIXING USE "AIRFIX" POLYSTYRENE CEMENT

1 FUSELAGE & INTERIOR ASSEMBLY

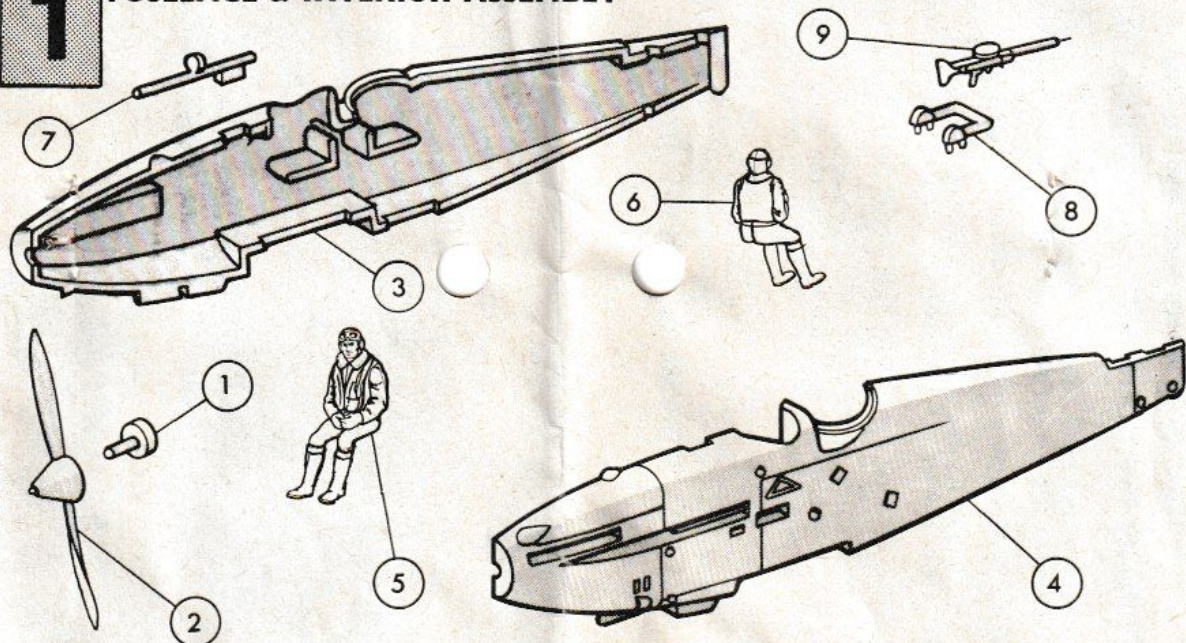

It is recommended that the instructions and exploded views 2. Cement port fuselage half (4) to starboard, ensuring no parts are best painted before assembly. IF STAND IS TO 3. Cement pilot (5) and gunner (6) onto seats within fuselage. BE USED CUT AWAY THE WALL OF PLASTIC FROM 4. Cement tab on gunsight (7) into slot in top of fuselage STAND SLOT IN FUSELAGE HALVES. 4. Cement locating cut outs on Scarff gun mounting (8) over moulded ring on rear cockpit.

1. Cement propeller shaft (1) into rear of propeller (2), when dry lay shaft into cut out in nose of starboard fuselage half (3). DO NOT CEMENT.
5. Cement machine gun (9) to mounting.

2 WING ASSEMBLY, ETC.

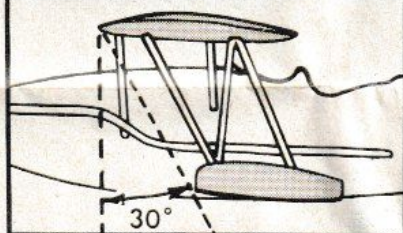
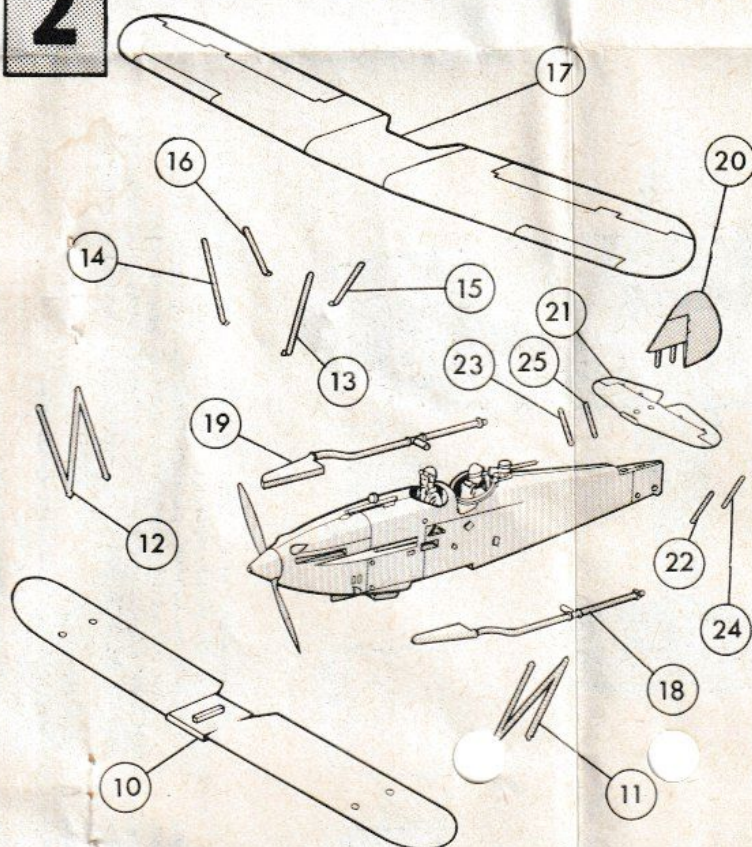

7. Locate and cement lower wing (10) to recess in underside of fuselage. Allow to dry.
8. Locate and cement interplane struts (11, 12) into locating holes in lower wing.
9. Locate and cement angled locating pins on centre section struts (13-16) into locating holes in fuselage sides, longer struts forward. Before the struts are firmly set, locate and cement in position to top wing (17) by applying cement into the locating holes on underside of top wing, ensure the wings are correctly aligned (see inset), set aside to dry.
10. Cement port and starboard exhausts (18, 19) into upper port and starboard slots in forward sides of fuselage, locating pins at rear of exhausts into locating holes in lower fuselage sides below cockpit.
11. Locate and cement locating pins on tail fin (20) into locating holes in tailplane (21) then cement protruding ends of locating pins into locating holes in rear of fuselage, allow to dry.
12. Locate and cement tail struts (22-25) into locating holes at rear of fuselage and undersides of tailplane.

3

UNDERCARRIAGE ASSEMBLY

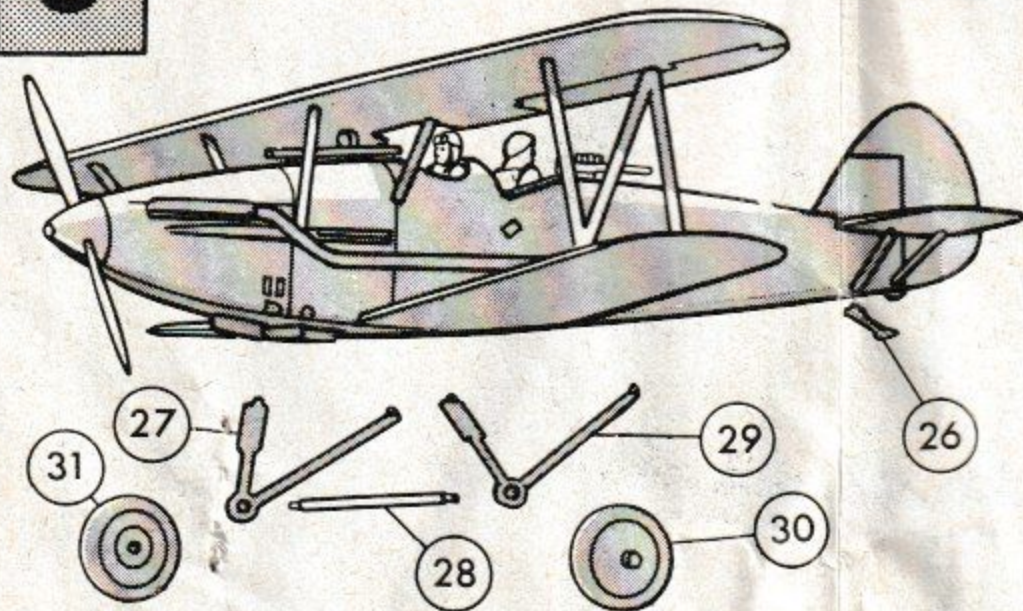

13. Locate and cement tailskid (26) in locating hole beneath rear of fuselage.
14. Cement starboard undercarriage leg (27) into locations beneath fuselage and wing, insert and cement axle (28) then similarly cement port undercarriage leg (29) in position and over opposite end of axle.
15. Locate and cement wheels (30, 31) onto protruding ends of axle. Painting should be completed at this stage.
16. If the model is to be displayed on stand, cement together both parts of stand.

4

COLOUR SCHEME

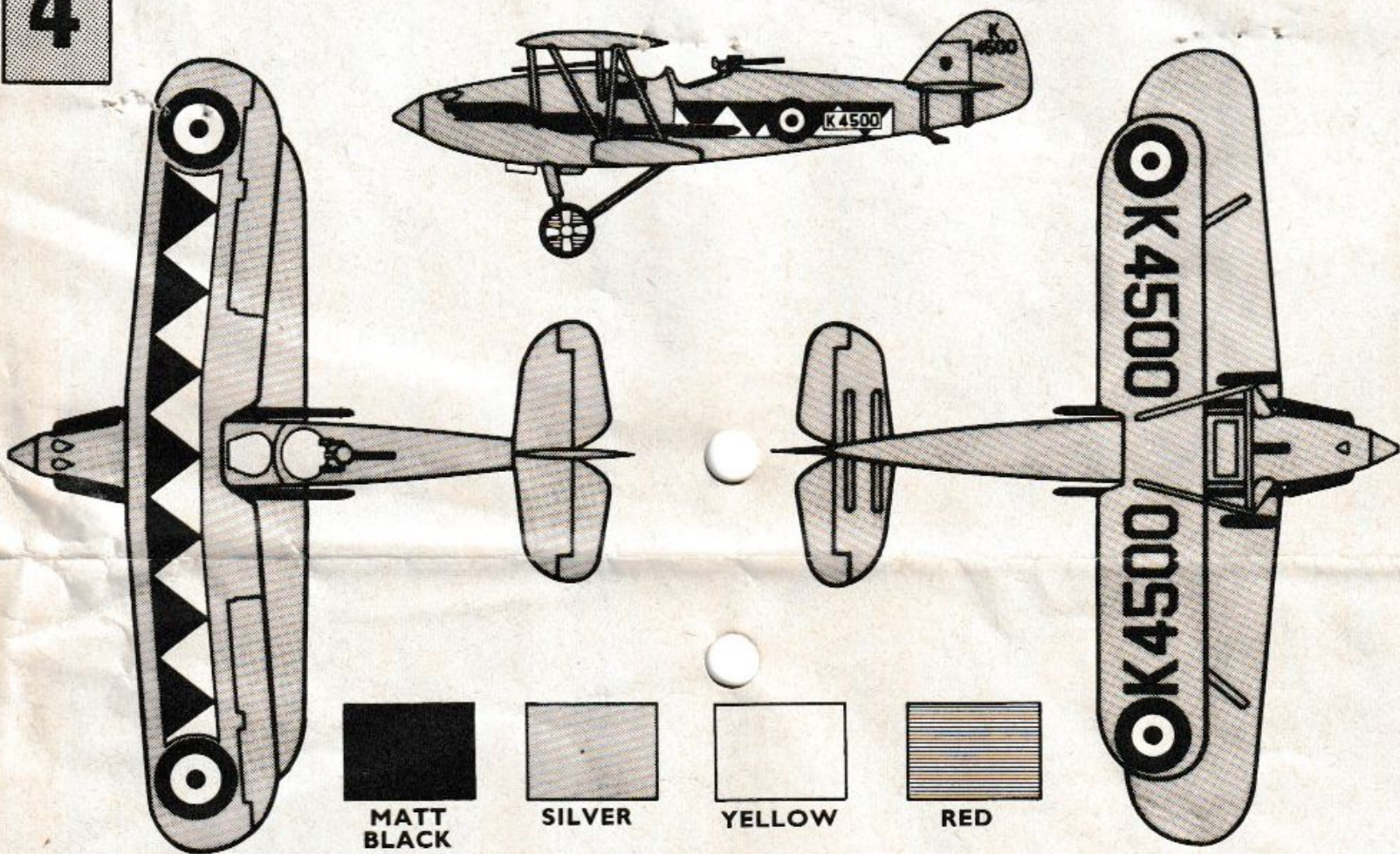

17. Cement arm of stand into slot provided in fuselage. Apply transfers. First cut the sheet into fourteen separate subjects. Then dip each in warm water for a few minutes, slide into position as indicated on the illustration. The large roundels with yellow and red 604 squadron markings are applied to the upper wing, the large roundels to the lower wing and the smallest roundels with yellow and red 604 squadron markings to the fuselage sides. The large serial numbers K4500 are applied beneath the lower wing, the port side to face the rear and the starboard the front. The

small black serial numbers K4500 either side of rudder. The red shield squadron badge to either side of fin. The Squadron Leader's pennant below front of cockpit on either side of fuselage, the aircraft name to base of stand.

SILVER G8 Complete aircraft except for items detailed below.
MATT BLACK M6 Tyres, machine gun, mounting, exhausts, gun sight.

RED G1 with
YELLOW G2. Segments on wheels.
BROWN G9 Propeller.
BLUE M11 Crew's overalls.