

MiG-21MF

eduard

1/48 Scale Plastic Model Kit

WEEKEND
edition



item # 84177

The MiG-21 was the most-produced supersonic fighter in the world and served with more than fifty Air Forces over four continents. This tiny interceptor or fighter-bomber played remarkable role in many wars and local conflicts from sixties to eighties, allowing many pilots to achieve their ace combat status.

The MiG-21 was one of a long-list of Mikoyan-Gurevich designs integrated into the armed forces of the Soviet Union, the Warsaw Pact, and allied client states. Its predecessors included such notable types as the MiG-15, MiG-17, and the supersonic MiG-19.

The roots of MiG-21 project reach back to the first half of the fifties. In 1954, when the preliminary design study Ye-1 came to its end and was quickly replaced by the reworked Ye-2 prototype. Both had a swept wing. The first MiG design to feature the delta wing was the Ye-4 prototype, which took to the air for the first time on June 16, 1955. It was also demonstrated a year later at the Moscow airfield Tushino.

The new aircraft with the MiG-21 designation was the first successful Soviet design integrating fighter and interceptor characteristics. It was also quite light Mach 2 aircraft, although the long-lasting development was adding weight gradually. The design featured sleek fuselage with the front air intake and shock cone. This feature later limited future development due to the very small space available for the radar.

Cold War warrior

The first of the new line to enter production was the MiG-21F, which together with the MiG-21P and MiG-21F-13 represented the first generation of this line. These versions were in production through the end of the fifties and the beginning of the sixties. Subsequent versions included the PF, FL, PFM and R with production of these peaking at the end of the sixties. The production of third generation of the MiG-21 started in 1968 and included the most advanced versions of the type like the M, SM, MF, SMT or bis among others. Simultaneously, two-seat training versions were also produced designated MiG-21U, UM and US.

Production of the MiG-21 ended in 1985. The new aircraft came off Soviet production lines in Moscow, Gorky and Tbilisi, the MiG-21F-13 was also built under license in Czechoslovakia and the MiG-21FL, M and bis in India by Hindustan Aeronautics Ltd. The Soviet Union produced 10,645 examples of all versions, 194 were built in Czechoslovakia and 657 in India. That counts 11,496 aircraft produced.

Over the course of the Cold War, the opponents of the MiG-21 included the likes of the Northrop F-5 Freedom Fighter or the Dassault Mirage III. NATO assigned MiG-21 code reporting name "Fishbed", while the Soviet pilots called it "Balalaika" due to the shape resembling it with the Russian musical instrument.

Aces from Asia, Middle East or Africa

Outside of the Soviet Union, the type flew with a long list of nations on four continents (Europe, Asia, Africa and South America)

and participated in many conflicts and wars. The most remarkable combat use includes the Vietnam war, the Indo-Pakistan wars, the Cuban participation in Angola and in the Arab world's attempts to eliminate Israel. It is no wonder there were many pilots achieving their ace status flying one or more variants of MiG-21.

Thanks to the high volume of use and intensive combat actions, the Vietnamese pilots are topping the list of aces of MiG-21. The top of the ladder is occupied by Nguyen Ven Coc with nine kills with three eight-victory aces following: Mai Van Cuong, Nguyen Hong Nhi and Pham Thanh Ngan. Of the other nations the Syrian pilots Bassam Hamshun and Majid Zugbi both achieved seven kills flying MiG-21MF, while Adeb Al-Jarf had the same score with MiG-21FL and Egyptian pilots Ali Vajai, Sami Marei and Sami Marei scored five times.

In the interceptor role the MiG-21 served with the Soviet Union and other nations of the Warsaw Pact into the eighties when it began to be replaced by the MiG-23 in seventies and MiG-29 Fulcrum in eighties.

This kit: MiG-21MF

This plastic model kit represents the MiG-21MF, an export version of the MiG-21SM where the "M" signifies "modernizovaniy" (modernized) and the "F" "forsirovanniy" (with afterburner). The MiG-21MF lacked some of the "sensitive" avionics equipment of the SM version. On the other hand it also sported some improvements to its export predecessor, the MiG-21M, in several aspects. It was powered by more powerful Tumansky R-13-300 engine with afterburning and carried the Safir-21/RP-22 radar instead of less effective RP-21MA of MiG-21M. The MiG-21MF type was identified as Izdelye (series) 96F in factory documentation.

The production started in the Moscow factory No. 30, with first batch of 96 production aircraft in 1969 (it is believed these were shipped to Egypt). Starting from 1974 the production was shifted to the No. 21 factory in Gorky, where 231 aircraft were built before the production shifted to the MiG-21bis version in 1976.

Although the MiG-21MF was export version, several aircraft saw service with 234. GIAP (Guard Fighter Regiment) of VVS (Soviet Air Force) located at the Kubinka air base. The reason was quite simple – the unit was tasked with flight demonstrations for foreign clients and also with the official parade and display flights. The armament consisted of the GSh-23-2L 23mm cannon with 200 rounds. The underwing pylons could carry a combination of FAB bombs up to 500 kg caliber, UB-16-57 rocket pods, R-3S, Ch-66 or S-24 missiles, and R-60 air-to-air missile, including the R-60M. NATO assigned the MiG-21MF codename "Fishbed J".

ATTENTION



UPOZORNĚNÍ



ACHTUNG



ATTENTION



注意



Carefully read instruction sheet before assembling. When you use glue or paint, do not use near open flame and use in well ventilated room. Keep out of reach of small children. Children must not be allowed to suck any part, or pull vinyl bag over the head.



Před započítím stavby si pečlivě prostudujte stavební návod. Při používání barev a lepidel pracujte v dobře větrané místnosti. Lepidla ani barvy nepoužívejte v blízkosti otevřeného ohně. Model není určen malým dětem, mohlo by dojít k požití drobných dílů.

INSTRUCTION SIGNS * INSTR. SYMBOLS * INSTRUKTION SINNBILDEN * SYMBOLES * 記号の説明

OPTIONAL
VOLBABEND
OHNOUTSAND
BROUSITOPEN HOLE
VYVRTAT OTVORSYMETRICAL ASSEMBLY
SYMETRICKÁ MONTÁŽREMOVE
ODŘÍZNOUTREVERSE SIDE
OTOČITAPPLY EDUARD MASK
AND PAINT
POUŽIT EDUARD MASK
NABARVIT

PARTS



DÍLY



TEILE



PIÈCES



部品

PLASTIC PARTS

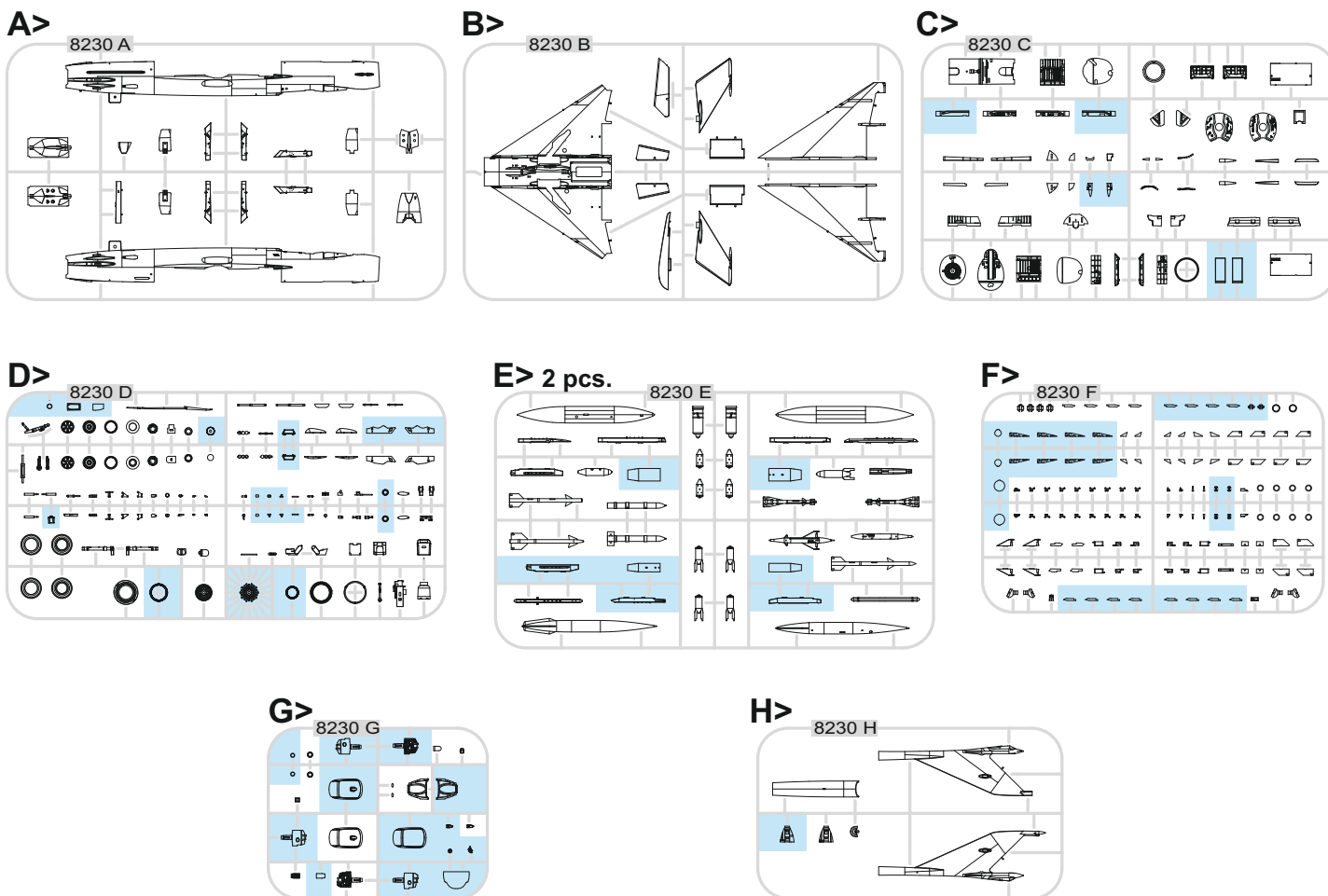

-Parts not for use. -Teile werden nicht verwendet. -Pièces à ne pas utiliser. -Tyto díly nepoužívejte při stavbě. - 使用しない部品

COLOURS



BARVY



FARBEN



PEINTURE



色

| GSI Creos (GUNZE) | | MISSION MODELS | |
|-------------------|----------|----------------|-----------------|
| AQUEOUS | Mr.COLOR | PAINTS | |
| H1 | C1 | MMP-001 | WHITE |
| H3 | C3 | MMP-003 | RED |
| H4 | C4 | MMP-007 | YELLOW |
| H5 | C5 | MMP-048 | BLUE |
| H11 | C62 | MMP-001 | FLAT WHITE |
| H12 | C33 | MMP-047 | FLAT BLACK |
| H15 | C65 | | BRIGHT BLUE |
| H26 | C66 | | BRIGHT GREEN |
| H27 | C44 | | TAN |
| H47 | C41 | MMP-012 | RED BROWN |
| H51 | C11 | MMP-063 | LIGHT GULL GRAY |
| H53 | C13 | | NEUTRAL GRAY |
| H60 | C16 | | GREEN |
| H70 | C60 | MMP-056 | GRAY |
| H77 | C137 | MMP-040 | TIRE BLACK |
| H78 | C38 | | OLIVE GREEN |
| H81 | C55 | MMP-023 | KHAKI |
| H84 | C42 | | MAHOGANY |

| GSI Creos (GUNZE) | | MISSION MODELS | |
|-------------------------|----------|----------------|---------------------|
| AQUEOUS | Mr.COLOR | PAINTS | |
| H90 | C47 | | CLEAR RED |
| H94 | C138 | | CLEAR GREEN |
| H313 | C313 | | YELLOW |
| H318 | C318 | MMP-070 | RADOME |
| H332 | C332 | | LIGHT AIRCRAFT GRAY |
| H338 | C338 | MMP-116 | LIGHT GRAY |
| H413 | C113 | MMP-090 | YELLOW |
| H417 | C117 | MMP-051 | LIGHT BLUE |
| H418 | C118 | MMP-055 | LIGHT BLUE |
| | C136 | MMP-032 | RUSSIAN GREEN |
| | C391 | | INTERIOR GREEN |
| Mr.METAL COLOR | | METALLICS | |
| | MC213 | MMM-006 | STAINLESS |
| | MC214 | MMM-001 | DARK IRON |
| | MC218 | MMM-003 | ALUMINIUM |
| Mr.COLOR SUPER METALLIC | | METALLICS | |
| | SM201 | MMC-001 | SUPER FINE SILVER 2 |
| | SM202 | | SUPER GOLD |

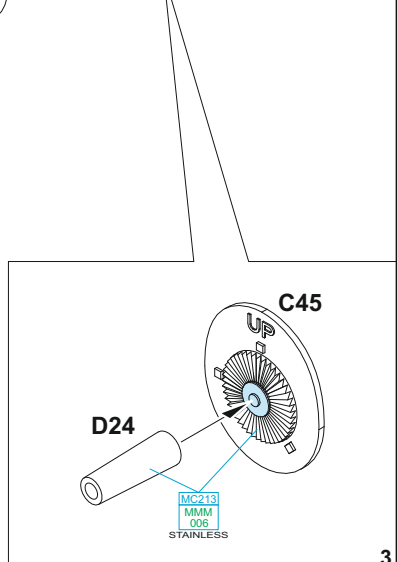
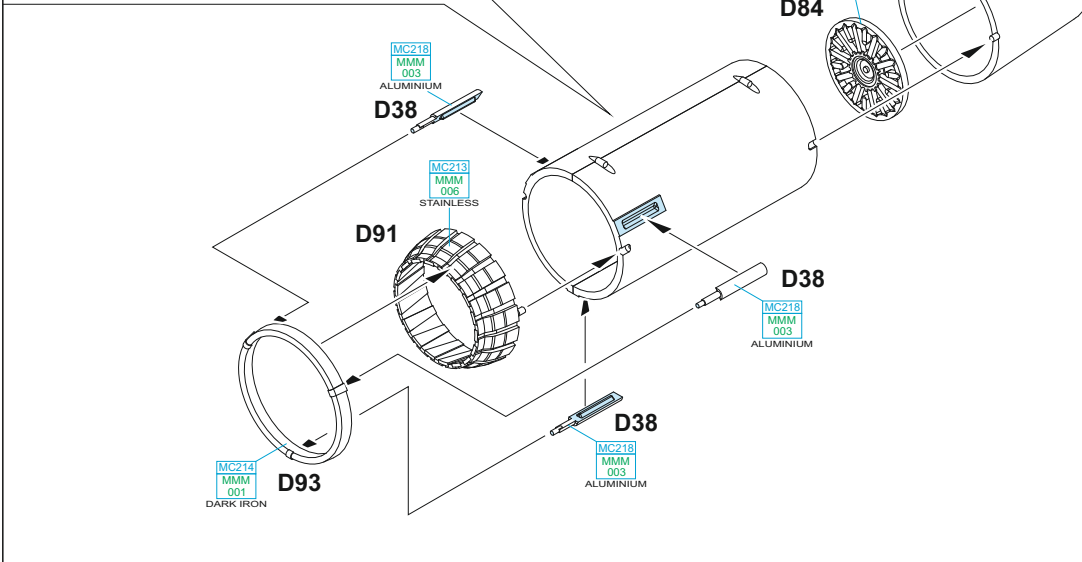
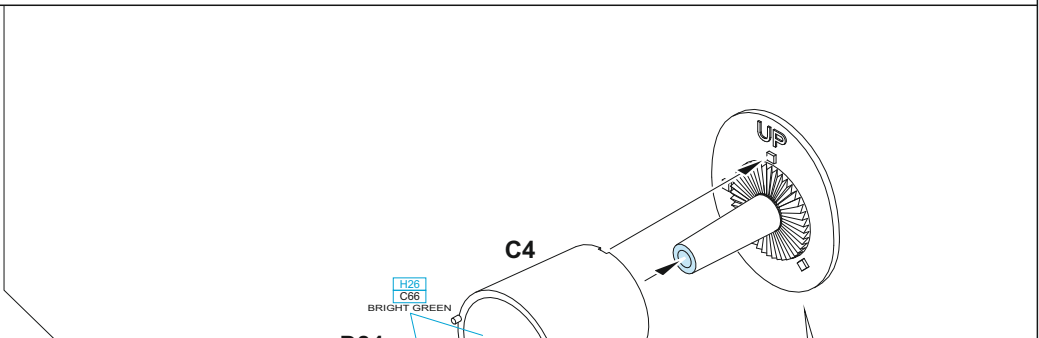
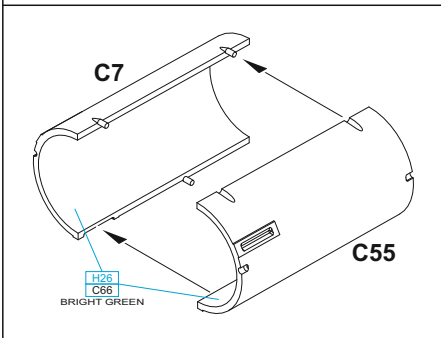
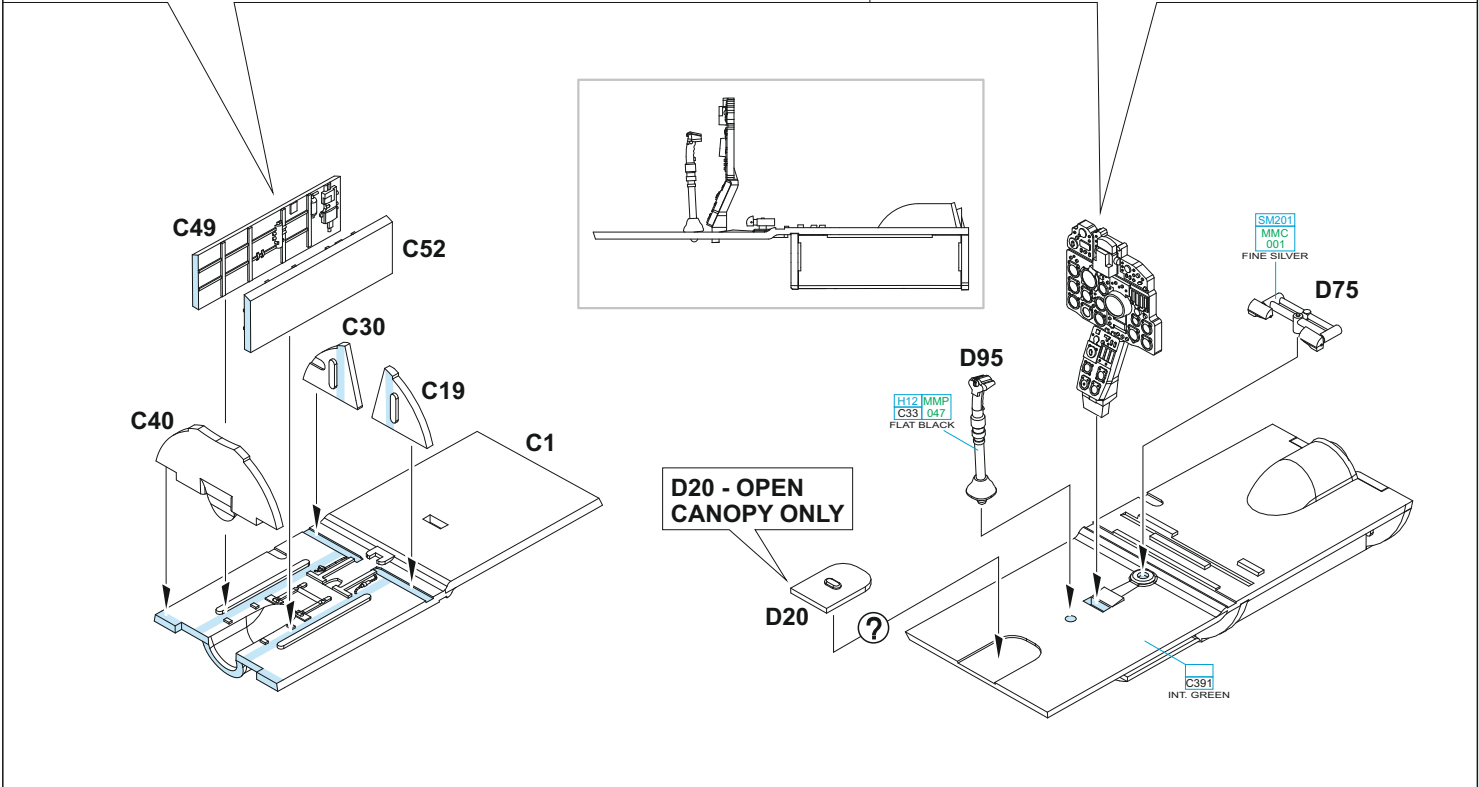
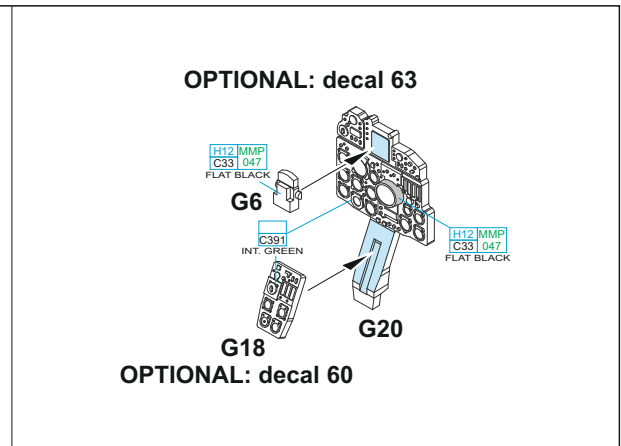
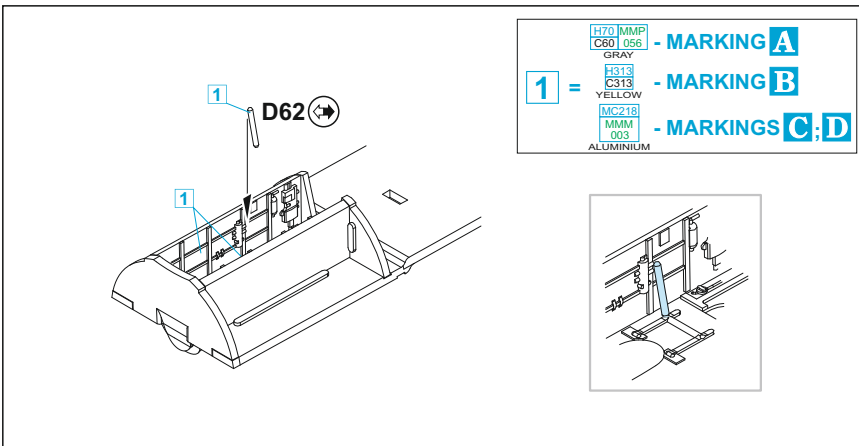

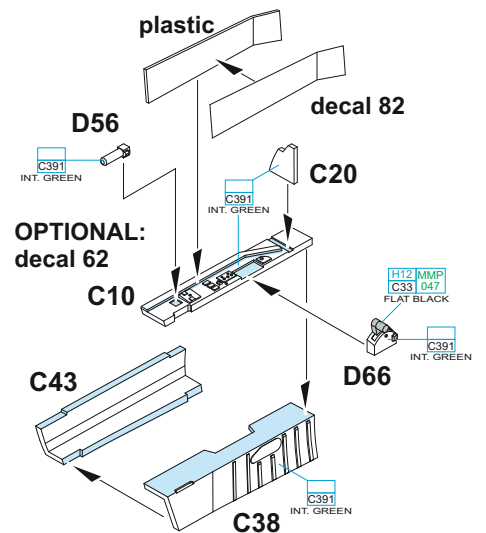
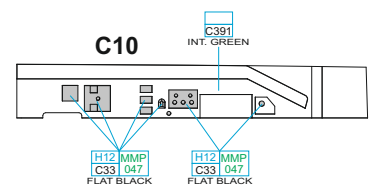
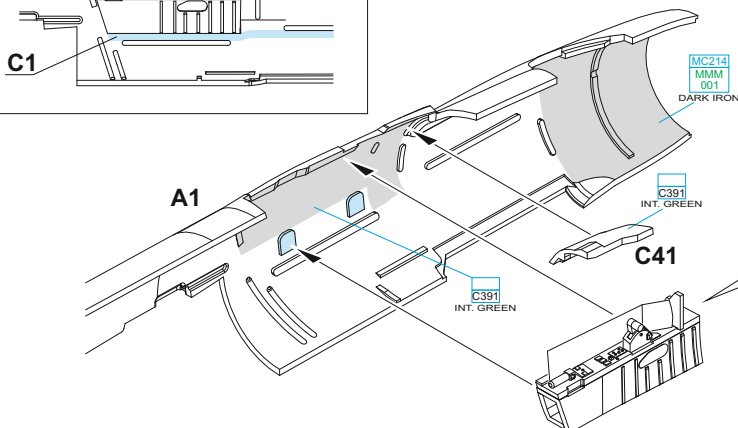
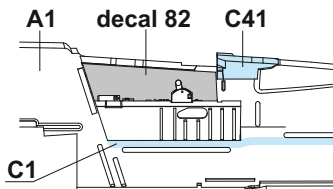
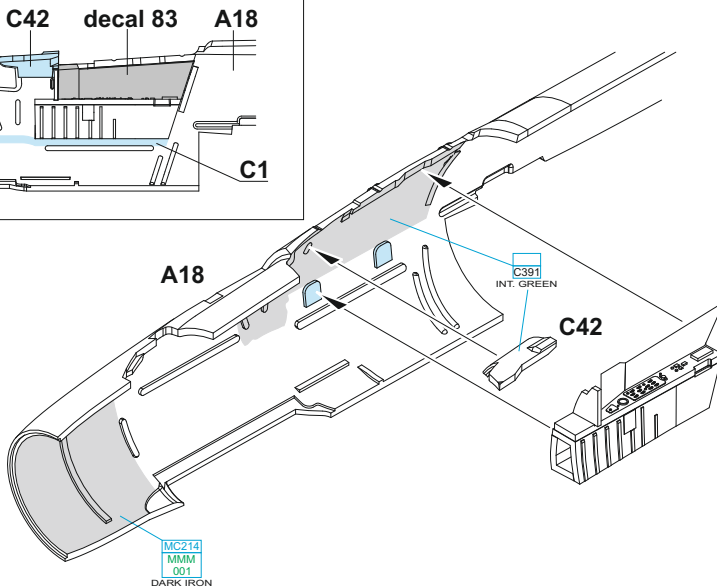
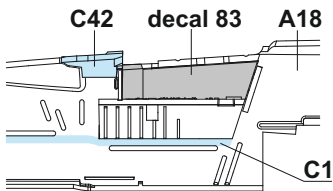
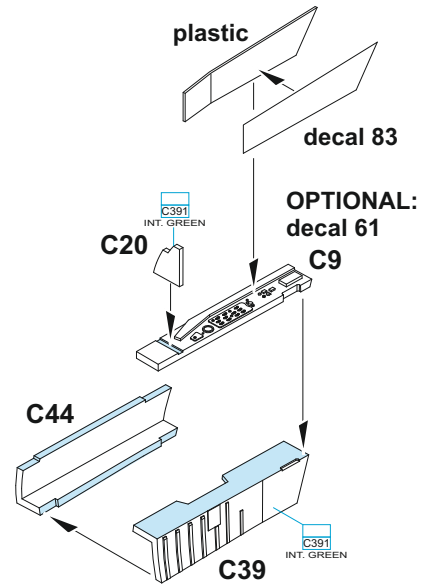
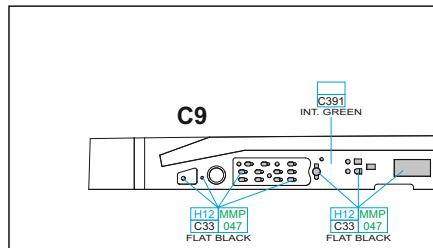
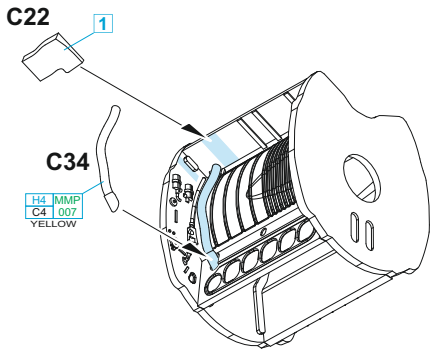
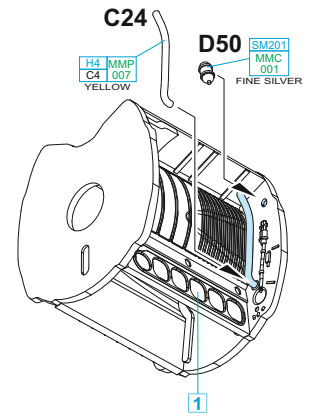
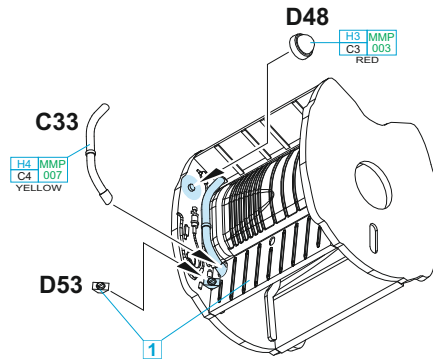
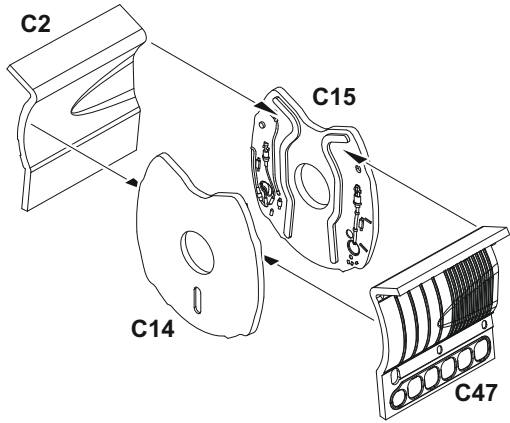

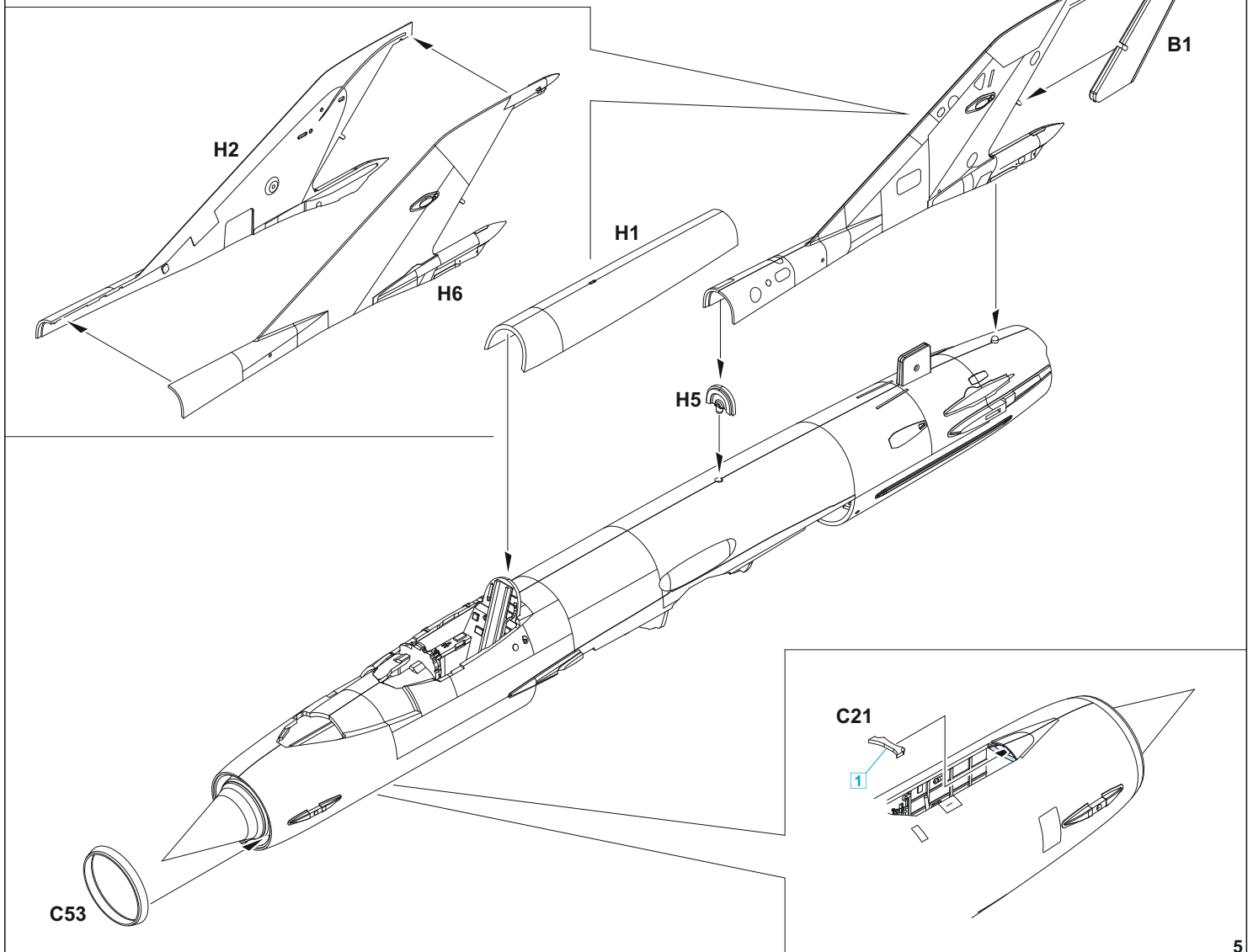
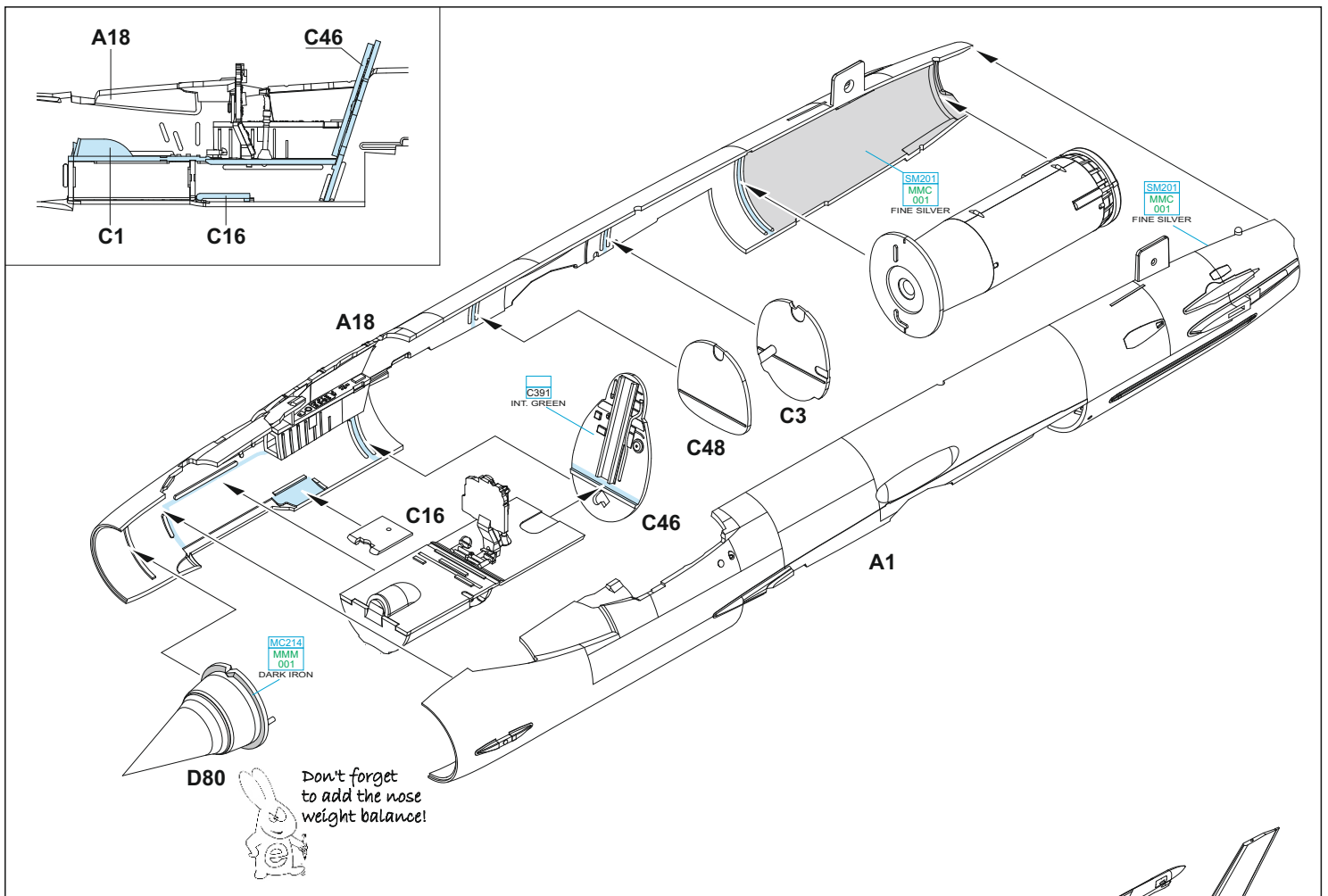

FOR OPEN AIR BRAKES ONLY

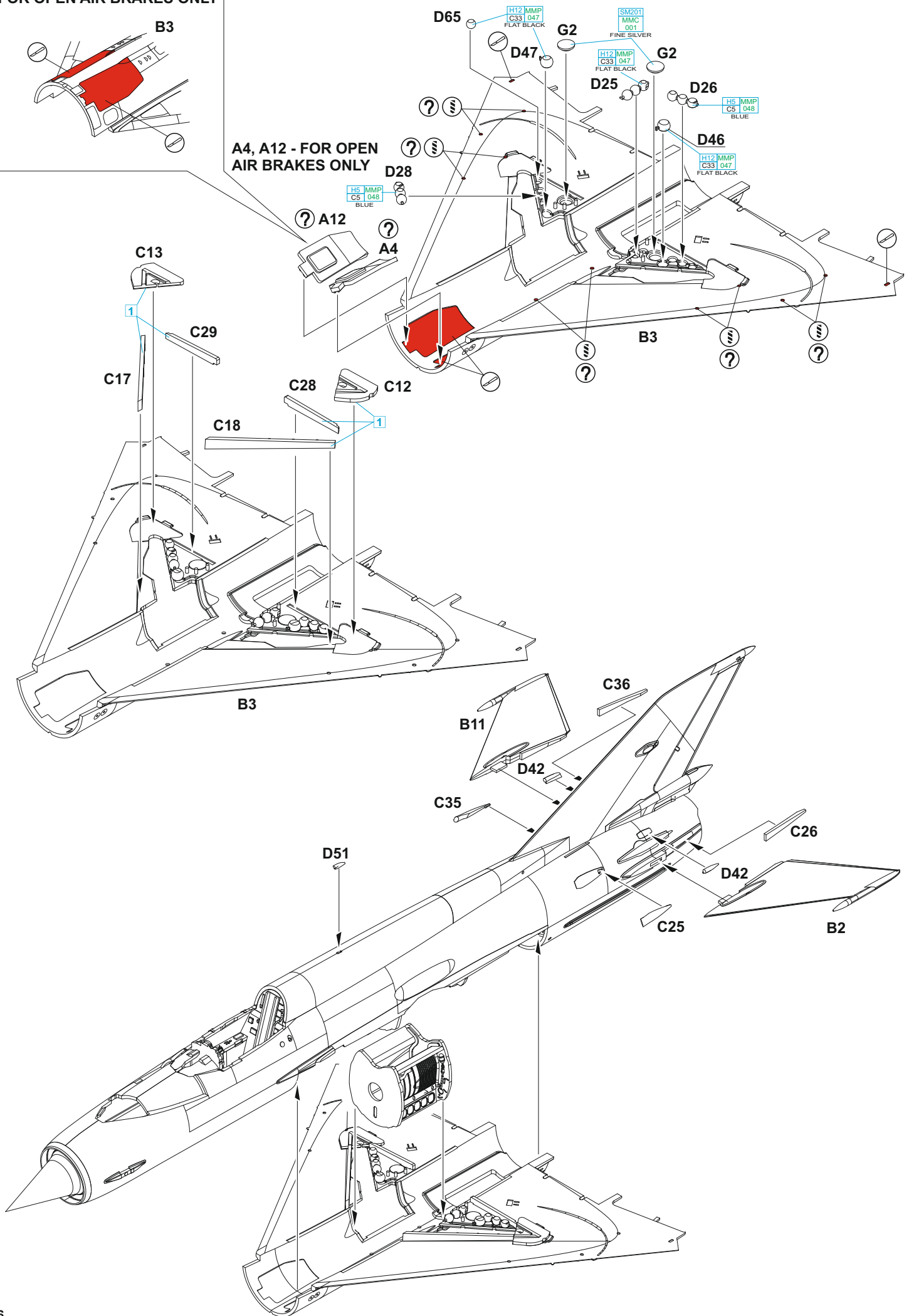

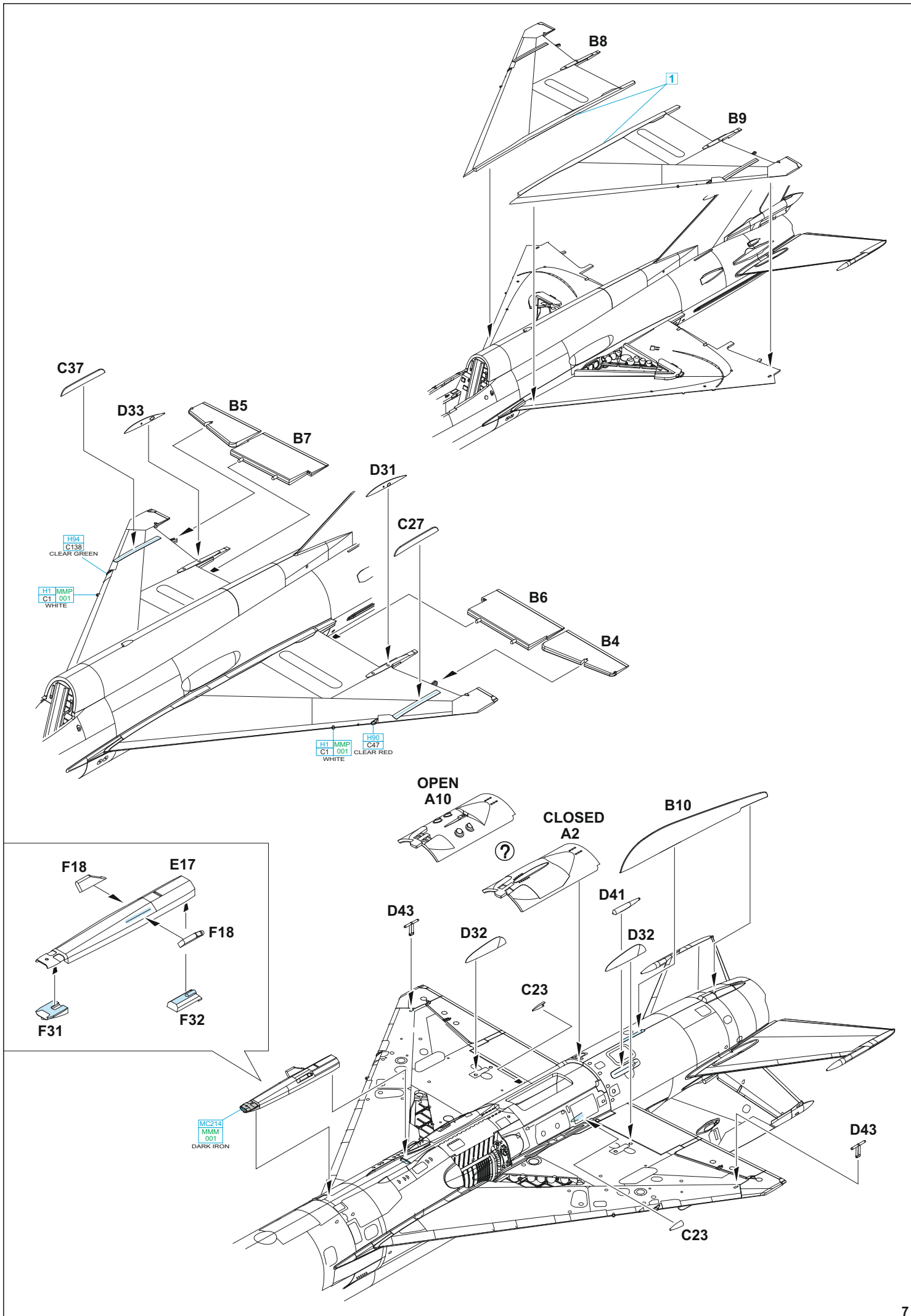

| | |
|-----------------------------------|-----------------------|
| H70 MMP C60 056 GRAY | - MARKING A |
| H47 MMP C117 051 LIGHT BLUE | - MARKING B |
| MC218 MMM 003 ALUMINIUM | - MARKINGS C;D |

OPEN AIR BRAKES

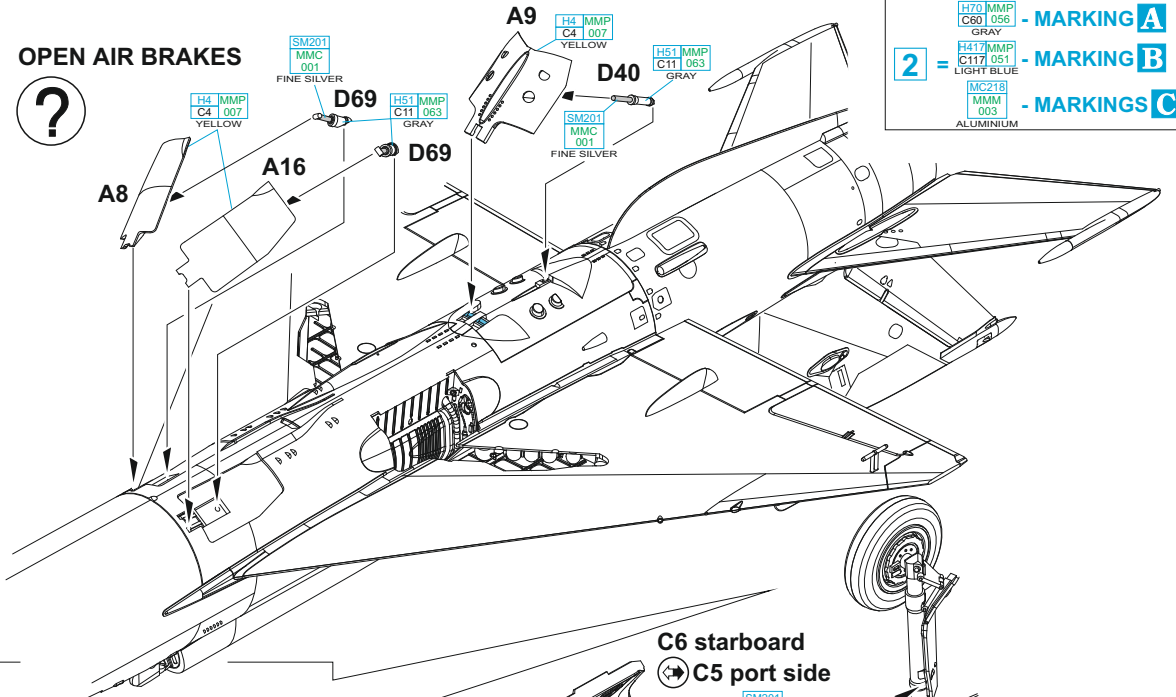
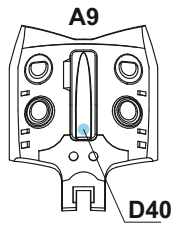

28°



**D12 starboard
D13 port side**

D13 - MARKING C ONLY

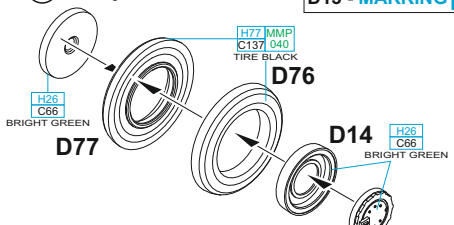

**D17 starboard
D18 port side**

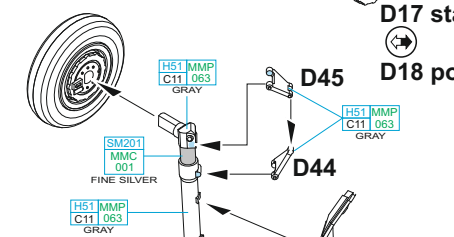

**starboard D79
port side D78**



**C6 starboard
C5 port side**

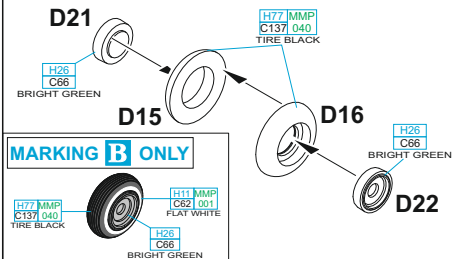
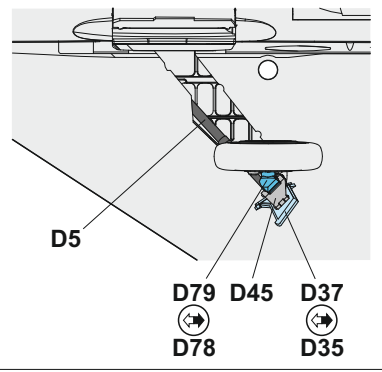
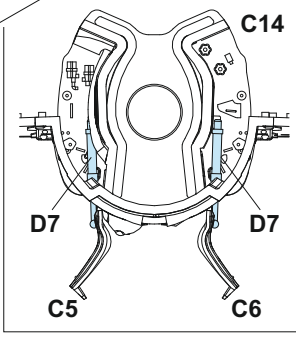
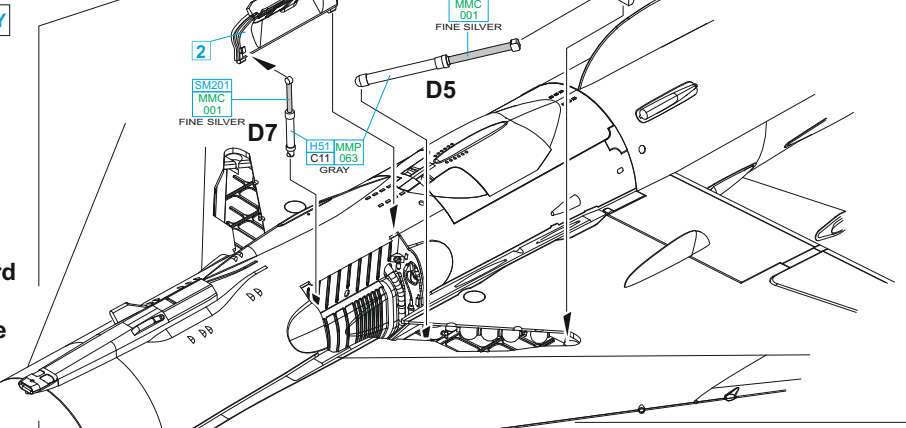

MARKING B ONLY

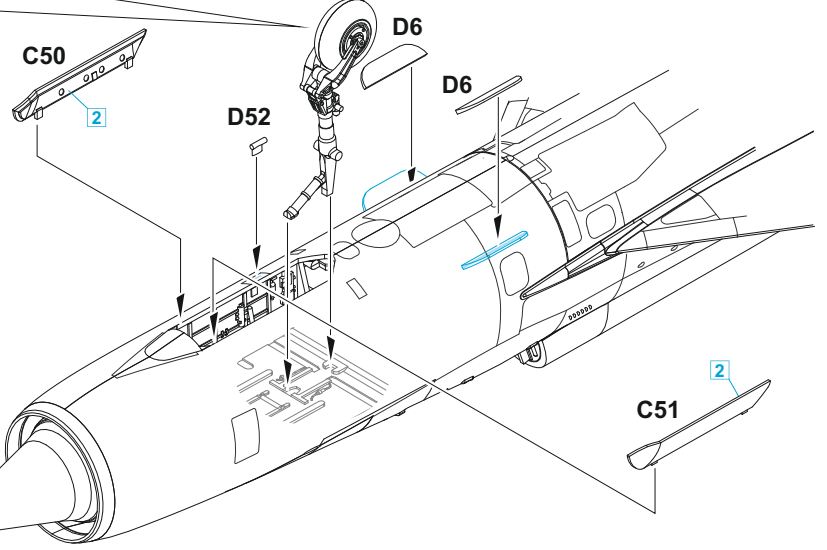
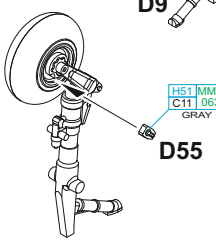
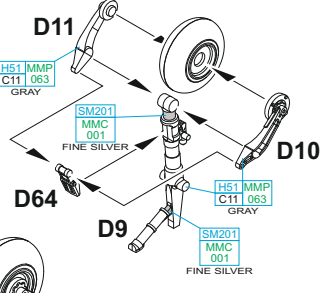

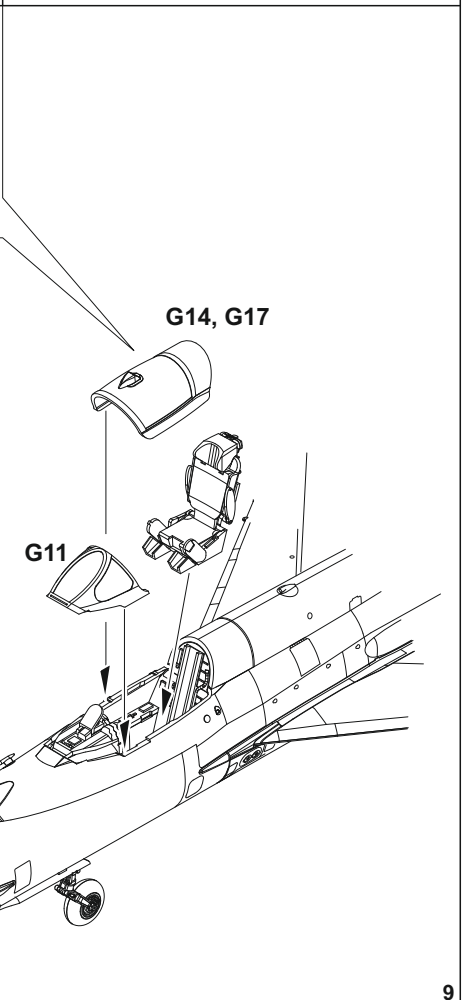
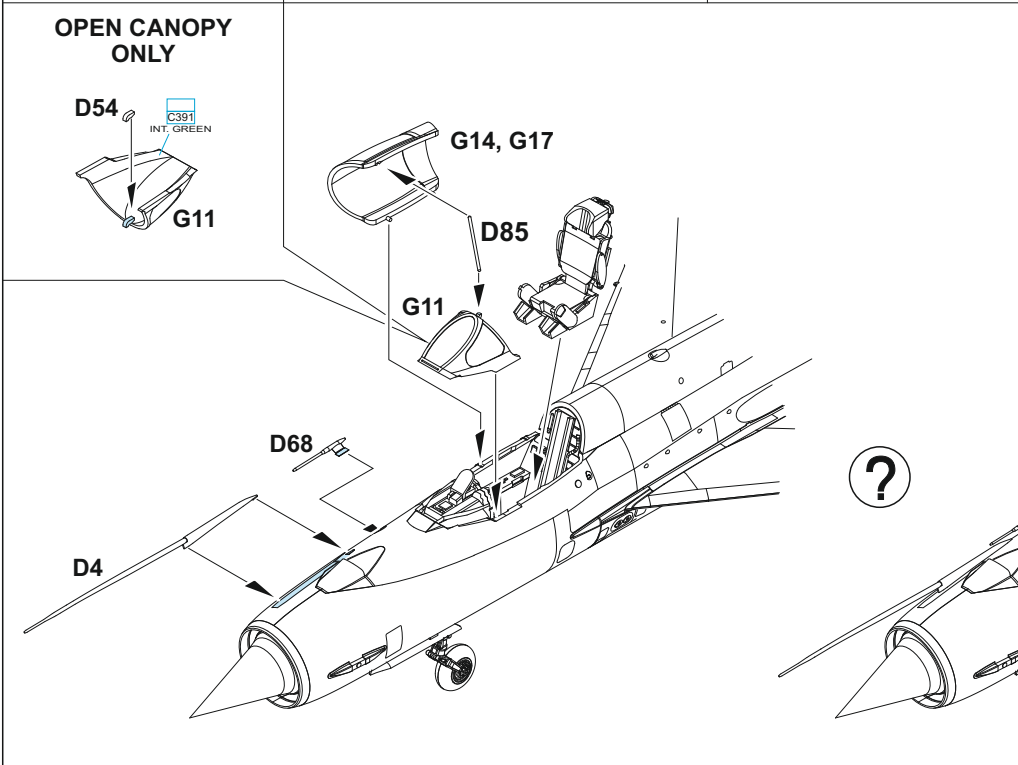
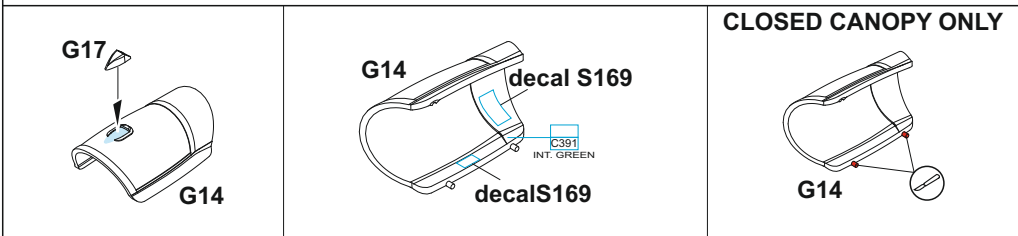
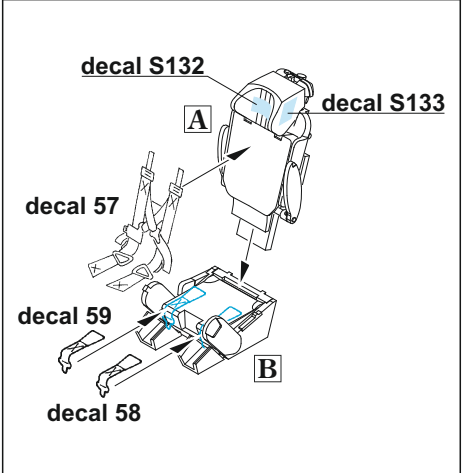
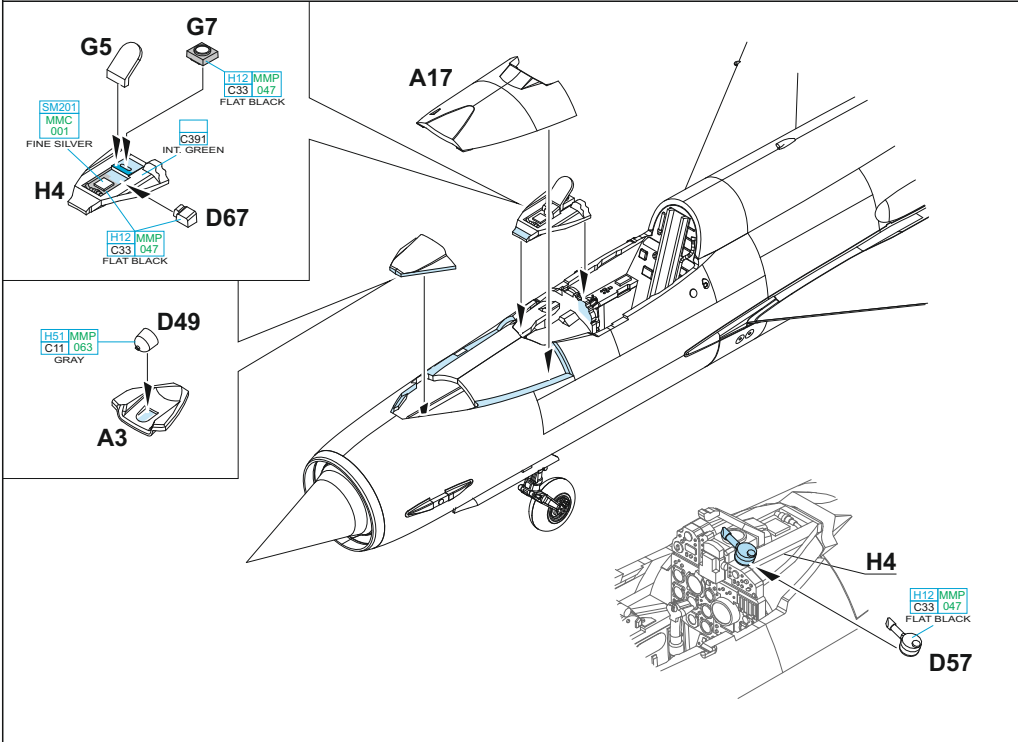
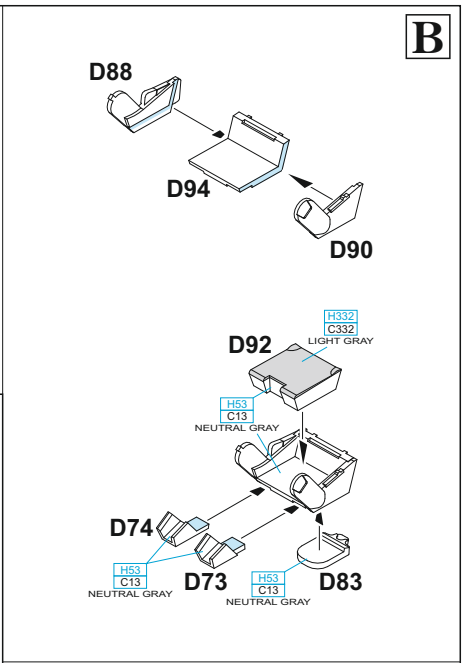
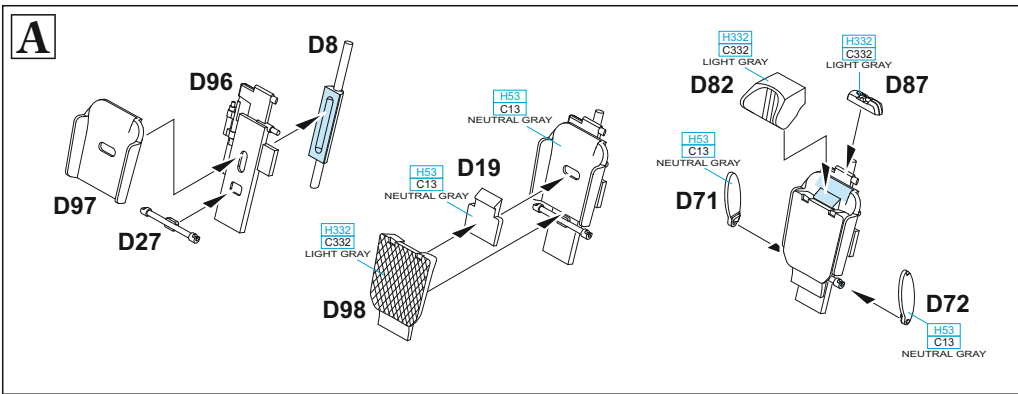

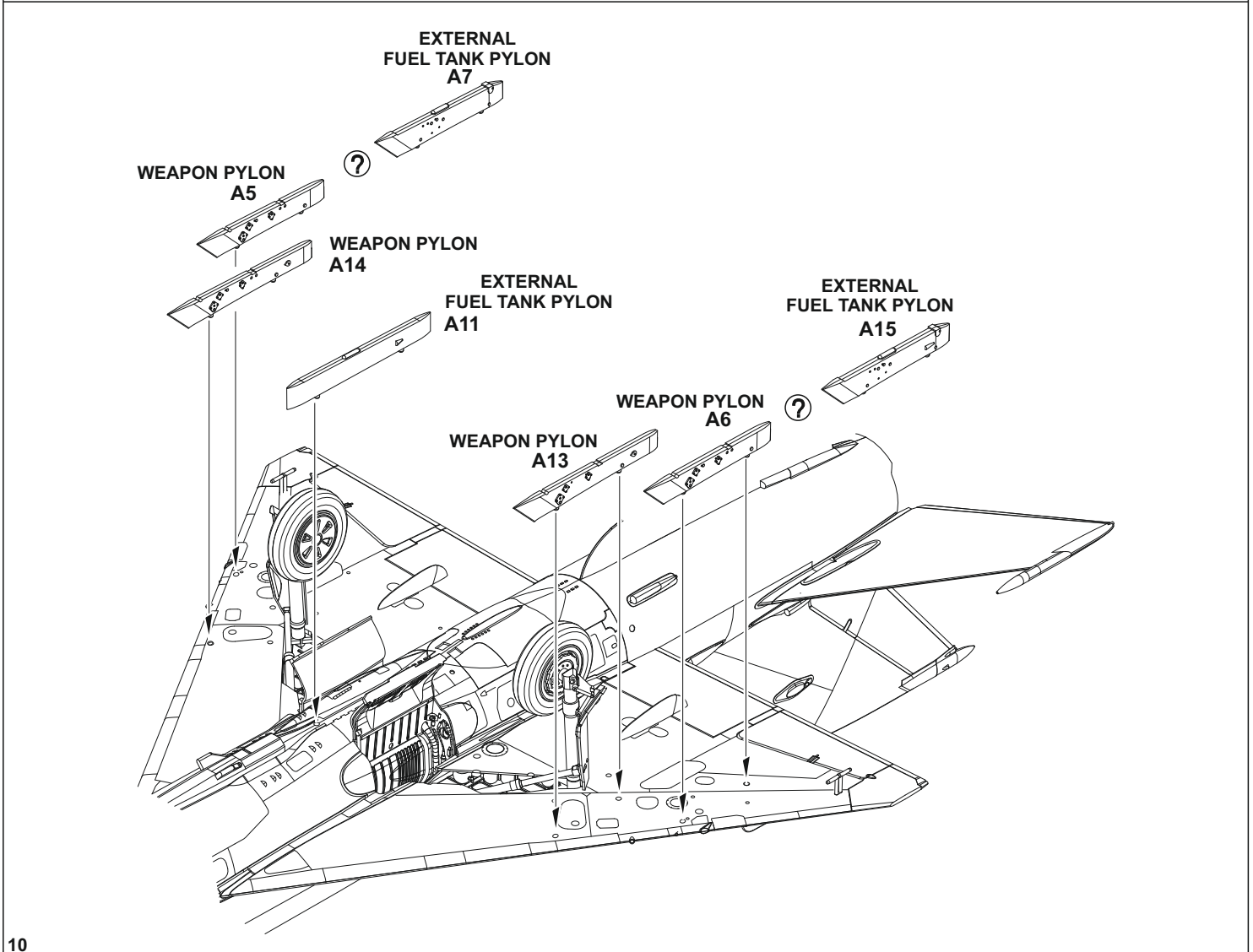
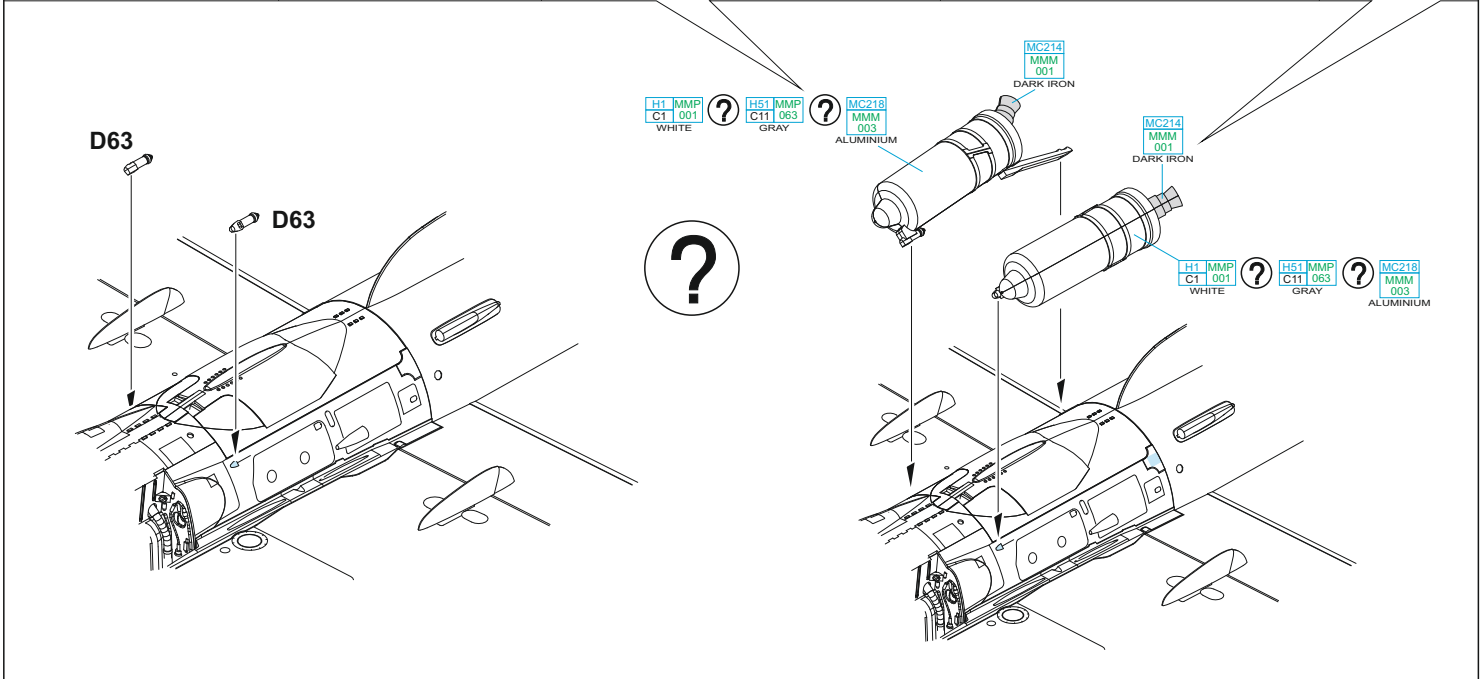
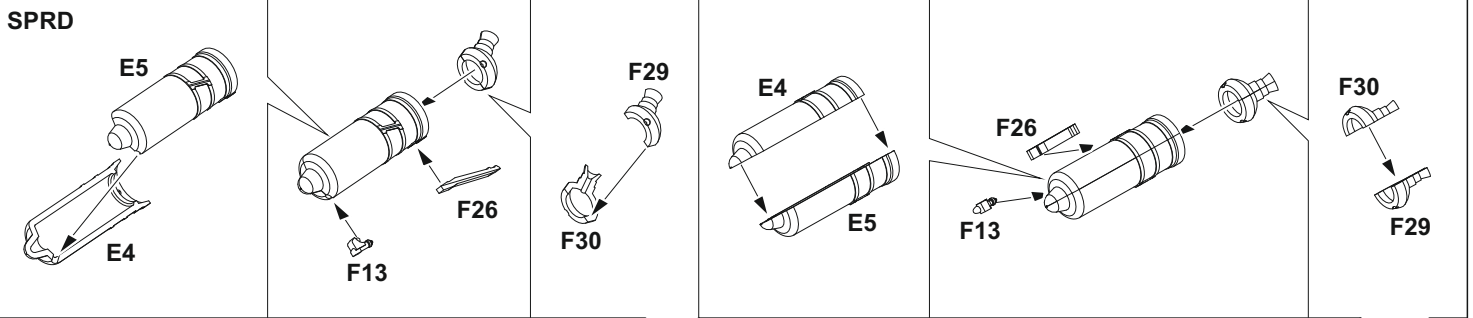

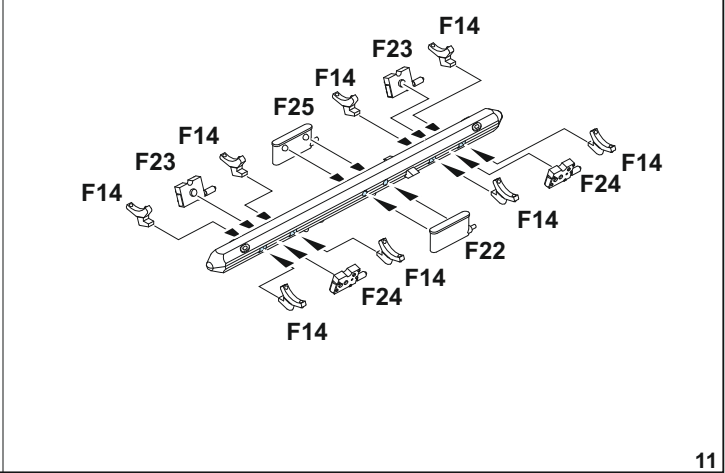
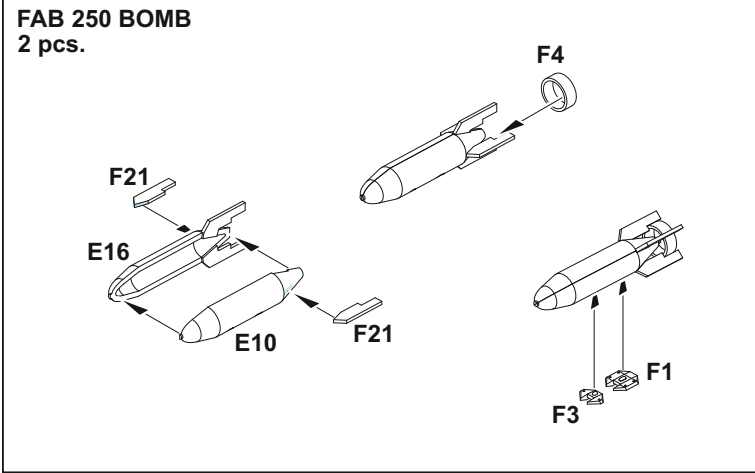
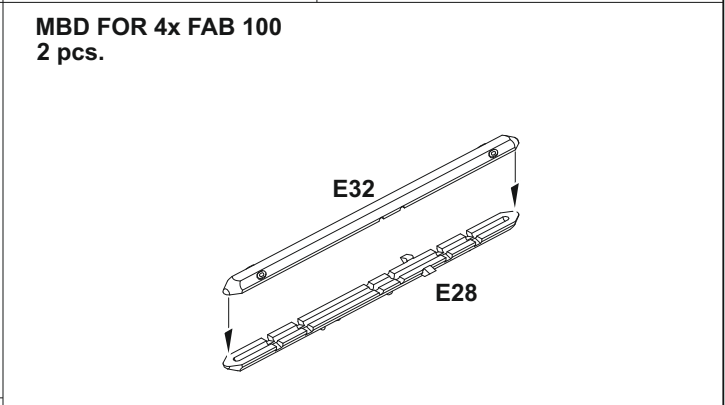
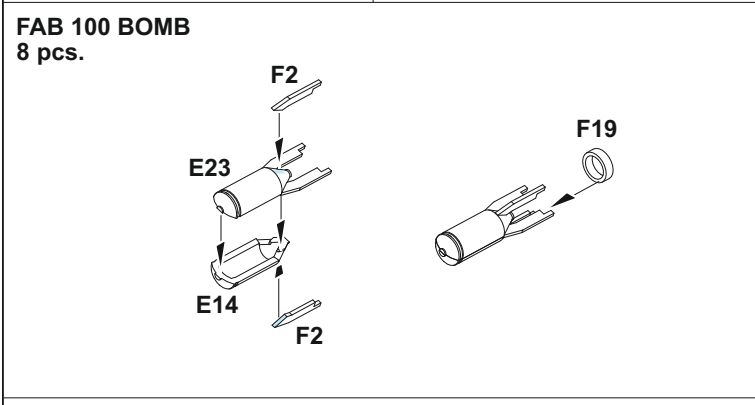
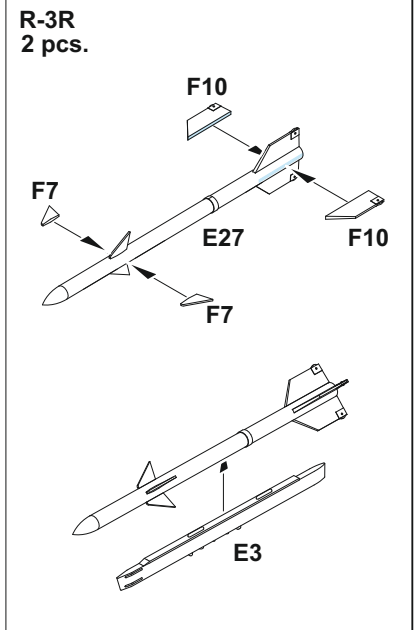
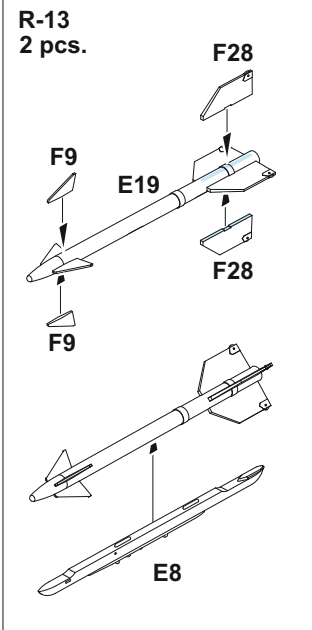
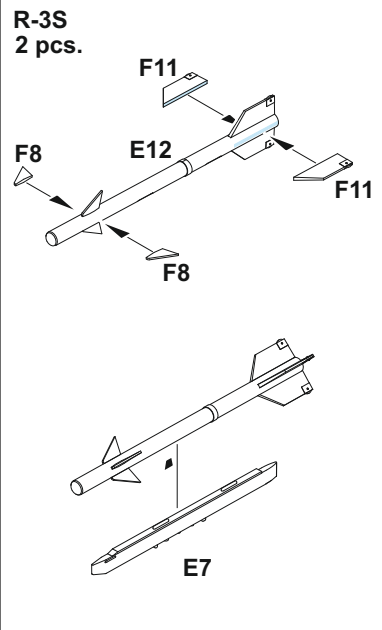
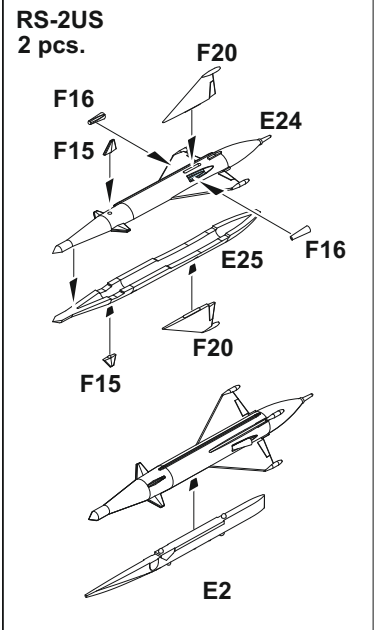
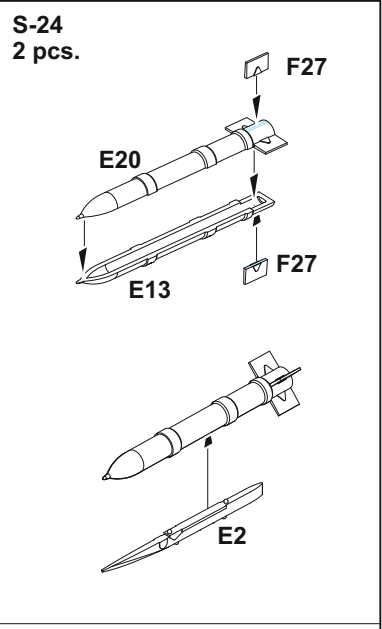
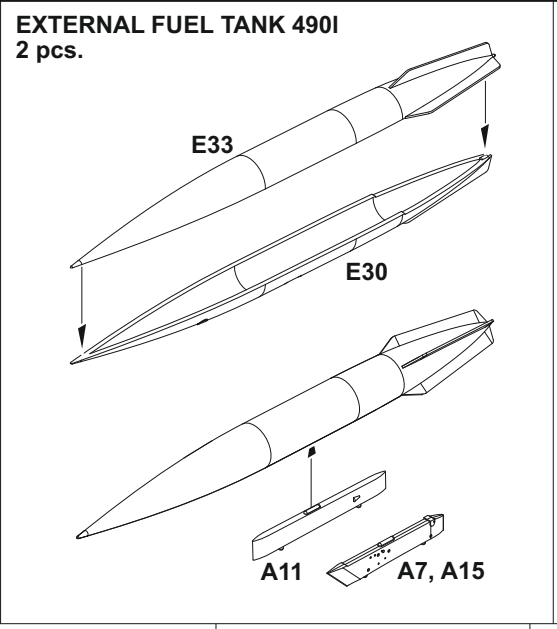
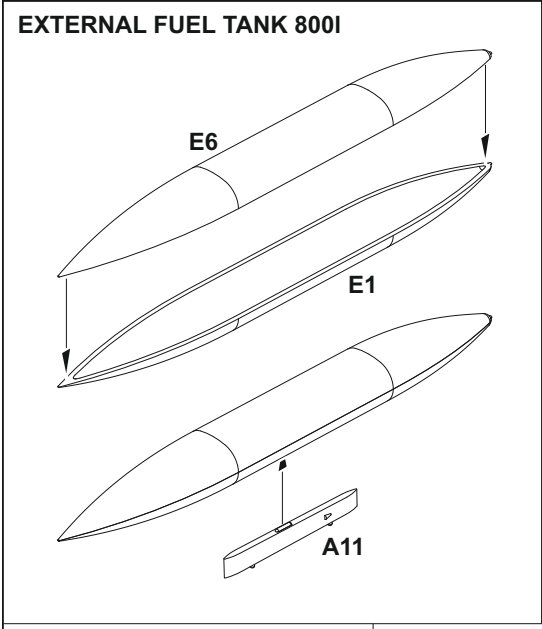

MiG-21MF

STENCILING POSITIONS

EXTERNAL FUEL TANK 800I

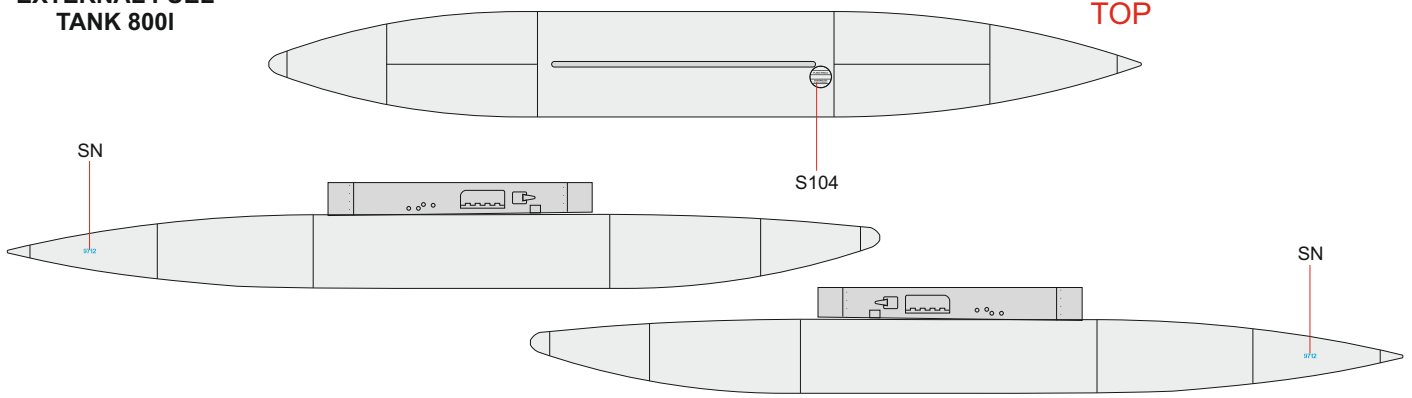

EXTERNAL FUEL TANK 490I

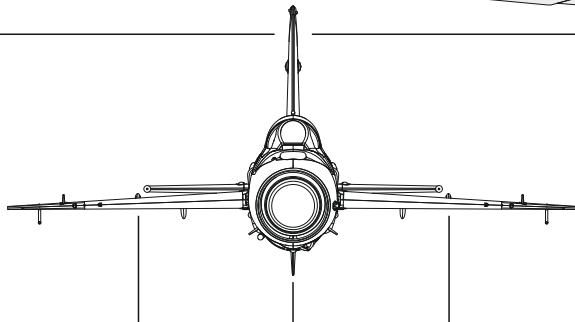
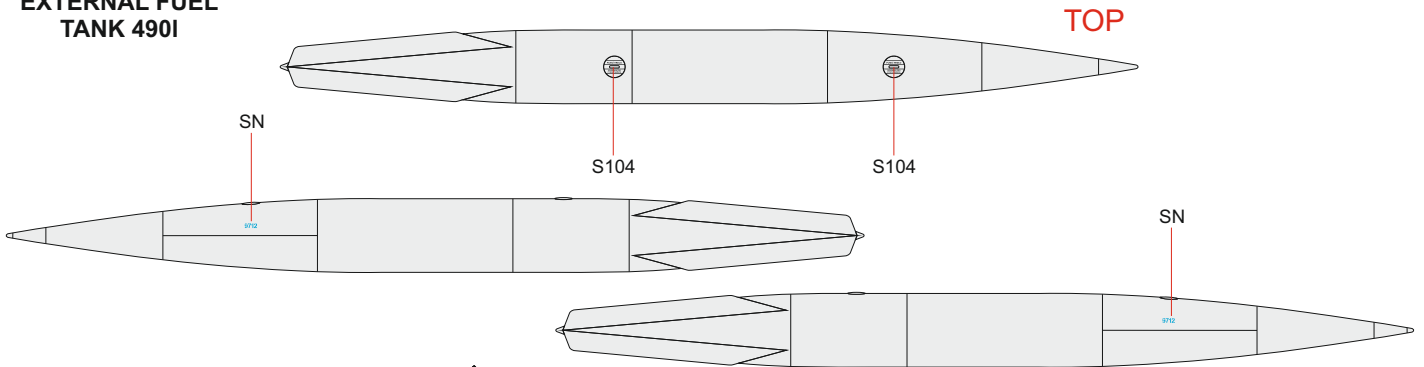

| | | |
|-------------------------|-----|----|
| EXTERNAL FUEL TANK 800I | A11 | |
| EXTERNAL FUEL TANK 490I | A11 | |
| EXTERNAL FUEL TANK 490I | A15 | A7 |

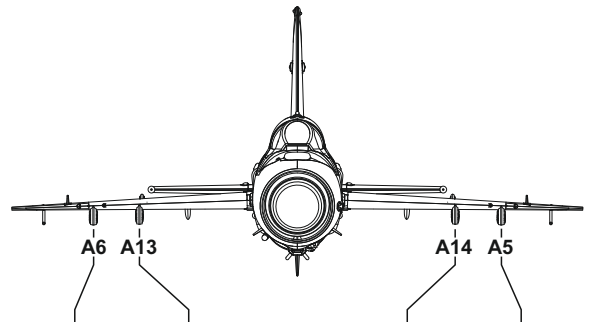

TO CHOOSE WEAPON AND EXTERNAL FUEL TANK OPTION PLEASE FOLLOW YOUR REFERENCE.

| | | | | |
|---------------------|--------|--------|--------|----|
| S-24 | E2 | E2 | E2 | E2 |
| RS-2US | E2 | E2 | E2 | E2 |
| R-3S | E7 | E7 | E7 | E7 |
| R-13 | E8 | E8 | E8 | E8 |
| R-3R | E3 | | | E3 |
| MBD | | F1, F3 | | |
| FAB 100 BOMB | | F1, F3 | | |
| FAB 250 BOMB | F1, F3 | | F1, F3 | |

A MiG-21M, 1st Squadron, 4th Fighter Air Regiment, Pardubice air base, Czechoslovakia, June 1989

The relaxing of the political strictness through 1989, along with the disbandment of Pardubice's 4th slp, gave rise to something as yet unheard of. Two more or less clothed ladies graced the noses of a MiG-21M. Greater scorn was provoked by the markings denoting 'Pardubice' and '4.slp' (translator's note: typically, the period behind the number is the equivalent to the English 'st', 'th' or 'nd', so that the 4. is equivalent to 4th, the 1. to the 1st, and so on), since these bits of information were still strictly classified. The inspiration for the artwork on '1113' was pin up on B-24 „Barbara Jean“ from the Second World War. The image was projected and transferred onto the aircraft with the use of a Meotar apparatus, and this aircraft made it into the air at least once with the pin-up in place. These aircraft were updated to MF standard likely during their general overhaul in 1987. They were given the rear view periscope mounted in the canopy and had the small wing fences added adjacent to the auxiliary air intake doors. The R-13 power egg was added already during the midlife upgrade. Aircraft after general overhauls in April 1986, retained their original look without paint, the wheel wells were a grey-green color, and the air brake interiors were painted their usual dense yellow color.

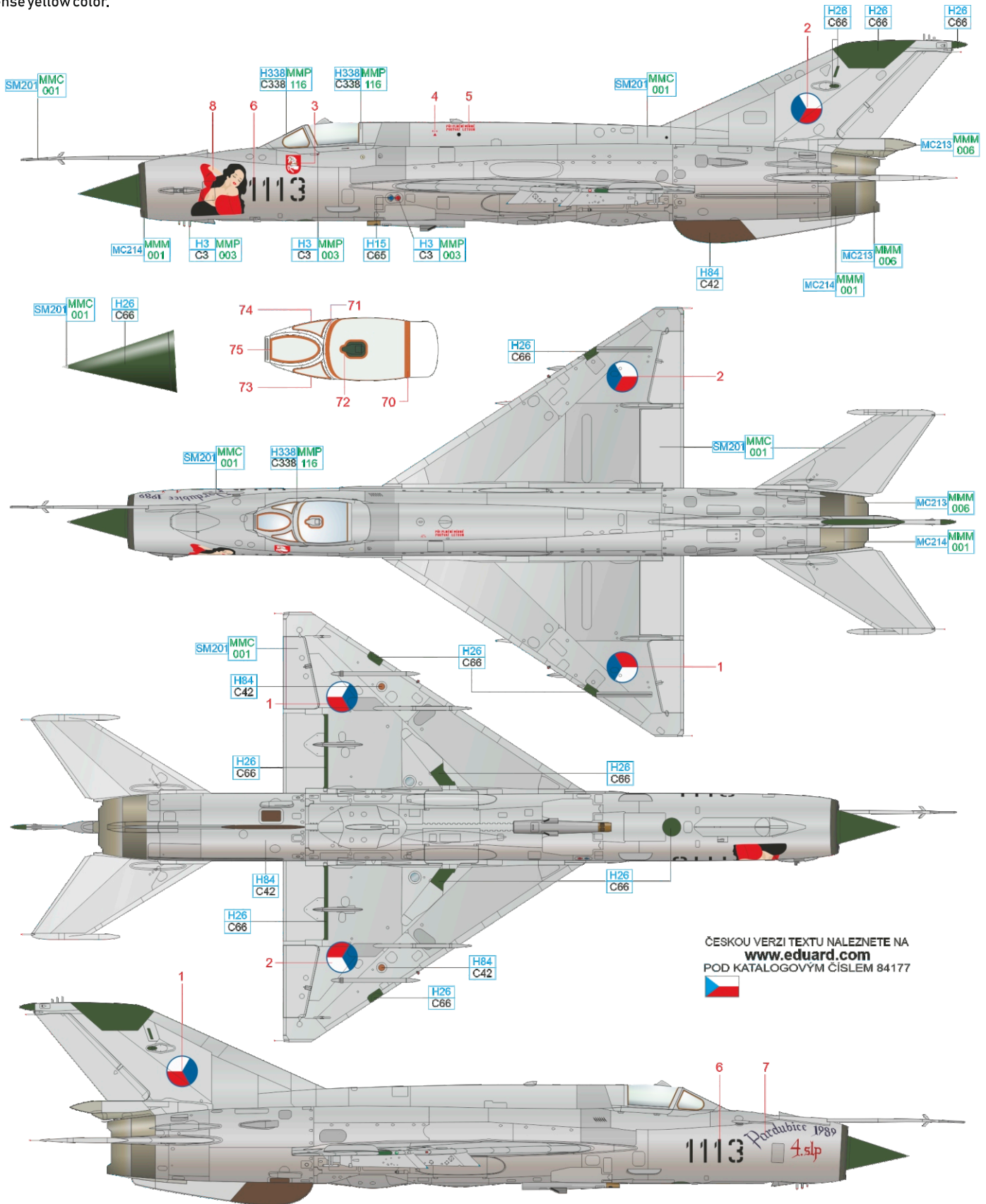

ČESKOU VERZI TEXTU NALEZNETE NA
www.eduard.com
 POD KATALOGOVÝM ČÍSLEM 84177



| | | | | | | | | | | |
|-------------------|-------|---------|------------|------|----------|-----|-------------|--------------|---------|-----|
| SUPER FINE SILVER | SM201 | MMC 001 | LIGHT GRAY | H338 | MMP C338 | 116 | STEEL | MC213 | MMM 006 | |
| DARK IRON | MC214 | MMM 001 | RED | H3 | MMP C3 | 003 | BRIGHT BLUE | H15 | C65 | |
| | | | | | | | MAHAGONY | H84 | C42 | |
| | | | | | | | | BRIGHT GREEN | H26 | C66 |

B No. 23+15, Jagdgeschwader 1, Holzdorf, Germany, 1990

After the reunification of Germany in 1990, all assets of the National Peoples' Army were absorbed into the Bundeswehr. In the case of combat aircraft, this included the MiG-21, -23, -29 and Su-22. Due to basic incompatibilities, the MiG-21 did not last long in the Luftwaffe. In 1990, the MiG-21MF served in the ranks of JG 1 and with one Staffel of JG 3. JG 1 was based at Holzdorf. It was here that MiG-21MF 23+15 (ex 510 of the East German Air Force) received the sharkmouth along with the other colourful markings.



| | | | | | | | | | | | | | | | | | |
|-------------------|-------|---------|------------|------|--------------|-------|-----|-------------|--------|------|--------------|--------------|-----|-----|----------|-----|-----|
| SUPER FINE SILVER | SM201 | MMC 001 | 29 | | | | | | | | | | | | | | |
| STEEL | MC213 | MMM 006 | LIGHT BLUE | H417 | MMP C117 051 | GREEN | H78 | MMP C38 021 | YELLOW | H413 | MMP C113 090 | BRIGHT GREEN | H26 | C66 | | | |
| DARK IRON | MC214 | MMM 001 | RED | H3 | MMP C3 003 | WHITE | H11 | MMP C62 001 | GRAY | H51 | MMP C11 063 | GREEN | H60 | C16 | MAHOGANY | H84 | C42 |

On May 7th, 1974, MiG-21MF, serial number 969107, was handed over to the Polish Air Force, along with another example. Up until January 9th, 1990, it served with the 41st PLM, after which it served with the 10th PLM. On the occasion of the fifty-fifth anniversary of the end of the Second World War, the upper and side surfaces were painted in gold. The author of this scheme was the crew chief, st.chor. Piotr Polit. In 2007, the aircraft was transferred to the Polish Air Force museum in Krakow. The gold paint on the upper and side surfaces was complimented by a commemoration of the anniversary together with the 1st Squadron unit marking, and the emblem of the 10th PLM on the nose. The lower surfaces remained in natural metal.

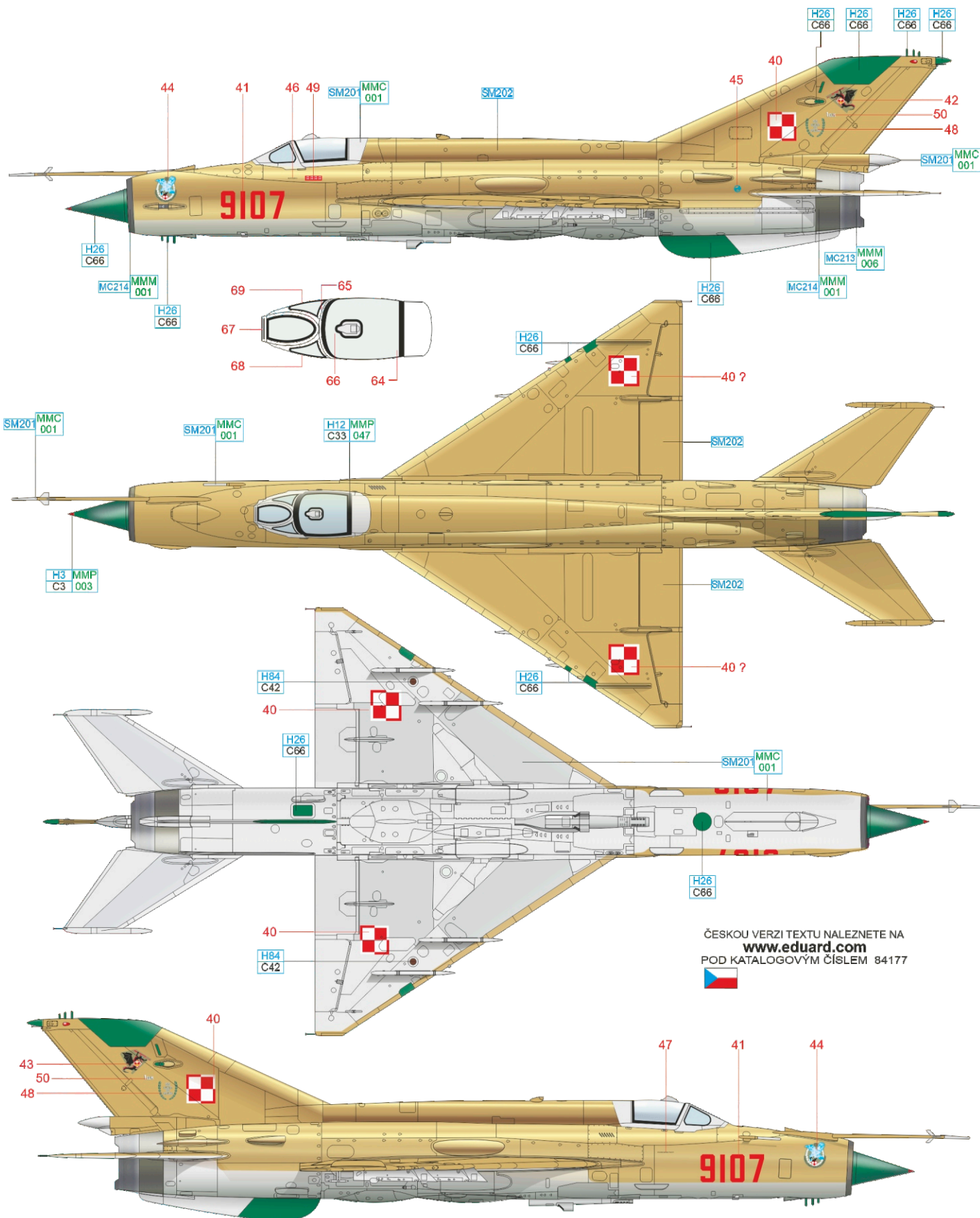

ČESKOU VERZI TEXTU NALEZNETE NA
www.eduard.com
 POD KATALOGOVÝM ČÍSLEM 84177



| | | | | | | | | | | | | |
|-------------------|-------|---------|-------|-----------------|----------|---------|--------------|---------|-----|---------------|------|-------|
| SUPER FINE SILVER | SM201 | MMC 001 | BLACK | H12 MMP C33 047 | MAHOGANY | H84 C42 | BRIGHT GREEN | H26 C66 | RED | H3 MMP C3 003 | GOLD | SM202 |
| STEEL | MC213 | MMM 006 | | | | | | | | | | |
| DARK IRON | MC214 | MMM 001 | | | | | | | | | | |

D No. 1019, 1st Lt. Sadik, No. 11 Squadron, Al Rasheed Air Base, Iraq, 1980

MiG-21MF numbered 1019 took part in the Yom Kippur War when it served as part of the expeditionary force with No. 11 Squadron when it was sent to Syria. On October 22nd, 1973, according to Arab sources unconfirmed by Israeli ones, Namiq Saadallah shot down an Israeli Mirage III. Seven years later, in the war with Iran, 1st Lt. Sadik shot down an Iranian F-4E Phantom II with an R-13M missile flying this airplane. The front of the aircraft carried the Arabic numerals 1019 and below the windscreen was a record of the kills achieved in this aircraft.

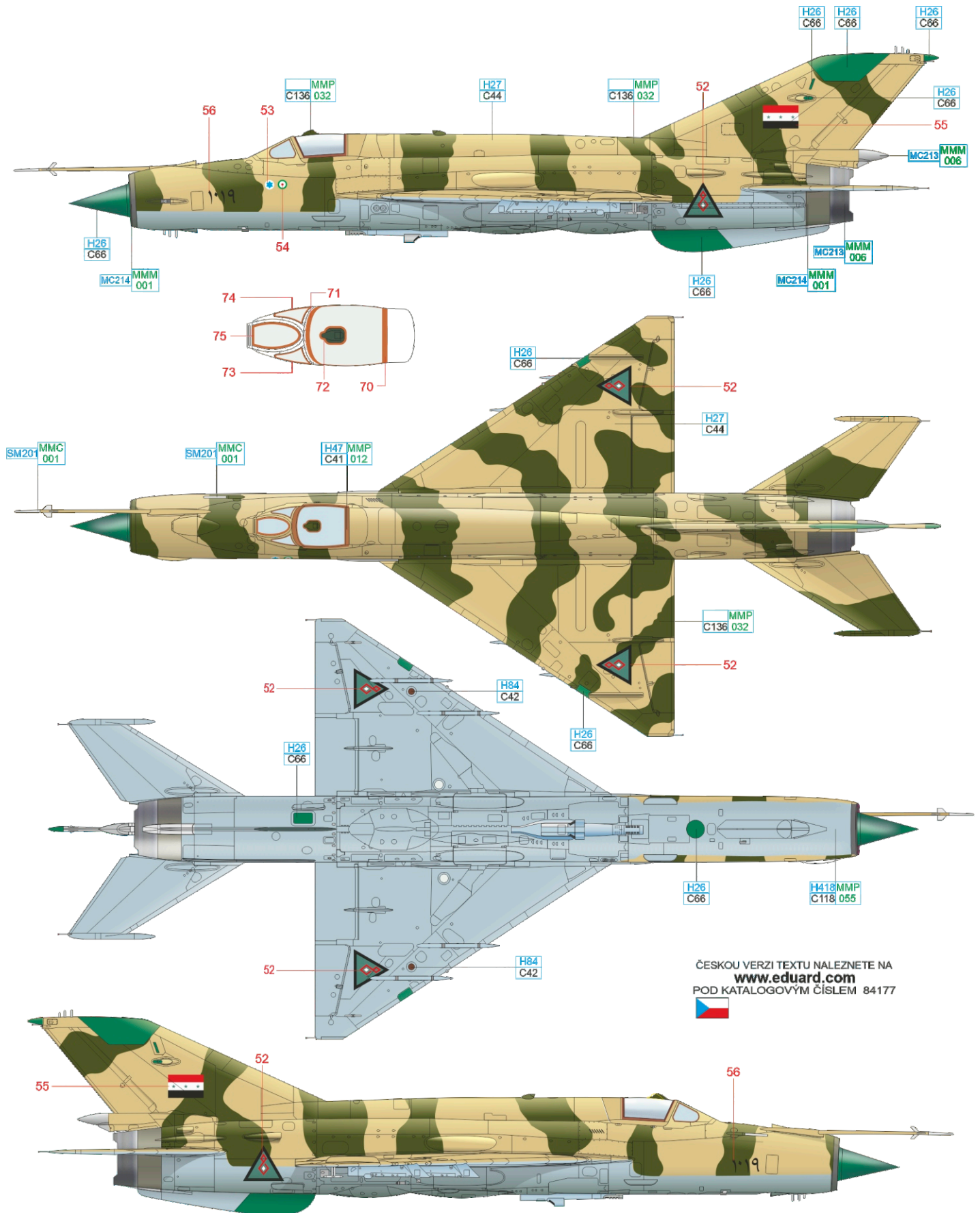

ČESKOU VERZI TEXTU NALEZNETE NA
www.eduard.com
 POD KATALOGOVÝM ČÍSLEM 84177



| | | | | | |
|-------------------|---------------|--------------|-----------------|----------|-------------------|
| SUPER FINE SILVER | SM201 MMC 001 | GREEN | MMP C136 032 | SAND | H27 C44 |
| STEEL | MC213 MMM 006 | LIGHT BROWN | H47 MMP C41 012 | MAHOGANY | H84 C42 |
| DARK IRON | MC214 MMM 001 | BRIGHT GREEN | H26 C66 | BLUE | H418 MMP C118 055 |

LEVÝ
VNĚJŠÍ PODKŘÍDLOVÝ
PALIVOVÝ
LEFT OUTSIDE
UNDERWING TANK PYLON

SN - SERIOVÁ ČÍSLA
MALÉ NA DRÁK LETOUNU
STŘEDNÍ NA ZÁVĚSNÍKY
VELKÉ NA RAKETNICE

SN - SERIAL NUMBER
SMALL FOR AIRFRAME
MEDIUM FOR PYLONS
LARGE FOR ROCKET LAUNCHERS

PRÁVÝ
VNĚJŠÍ PALIVOVÝ
PYLON
RIGHT OUTSIDE
UNDERWING TANK PYLON

PODTRUPOVÝ PYLON
FUSELAGE PYLON



S107



S105



S106



S108

LEVÝ VNĚJŠÍ PYLON
LEFT OUTSIDE PYLON

PRÁVÝ VNĚJŠÍ PYLON
RIGHT OUTSIDE PYLON



S17 ? S33 S109



S110



S110



S120 S17 ? S33

LEVÝ VNITŘNÍ PYLON
LEFT INSIDE PYLON

PRÁVÝ VNITŘNÍ PYLON
RIGHT INSIDE PYLON



S17 ? S33 S111



S112



S118



S119 S17 ? S33

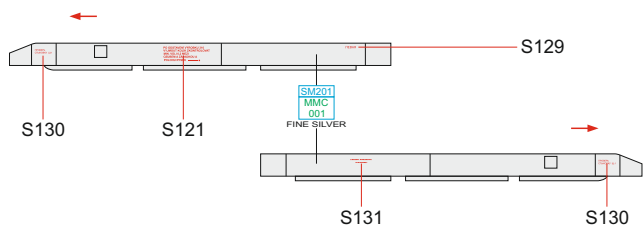

APU-13

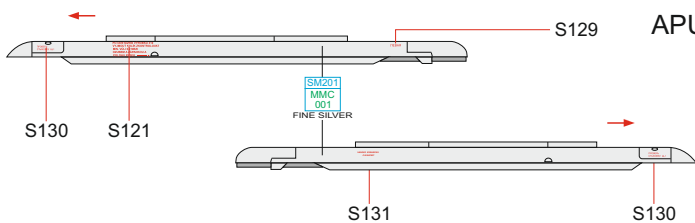
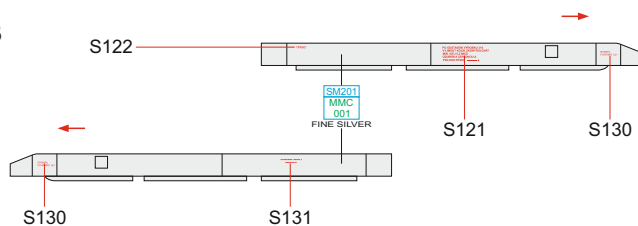

APU-13MT

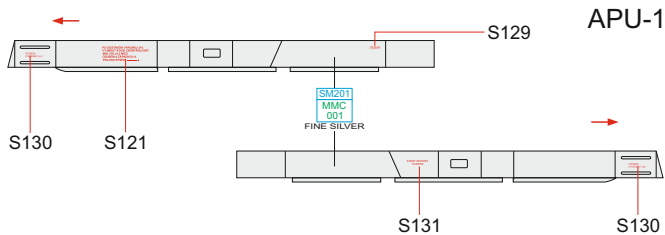
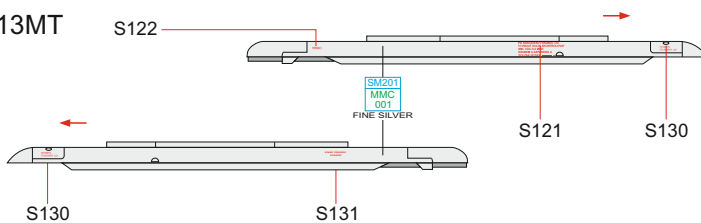

APU-13 FOR R-3R

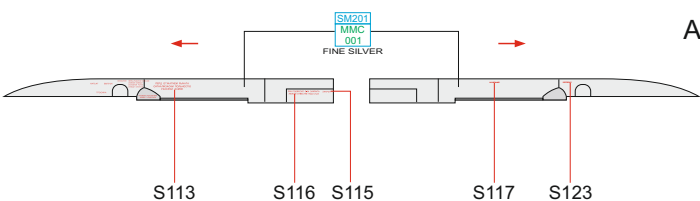
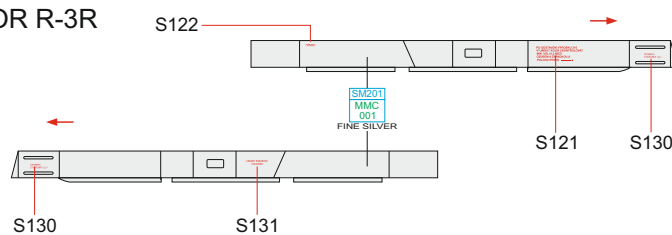

APU-7

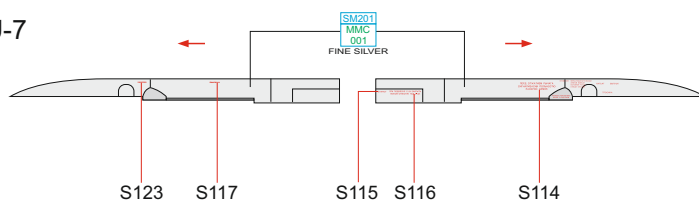

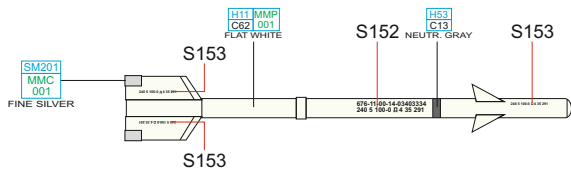

R-3S

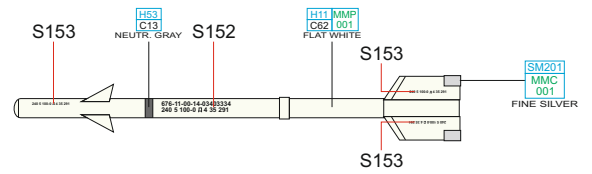

R-3R

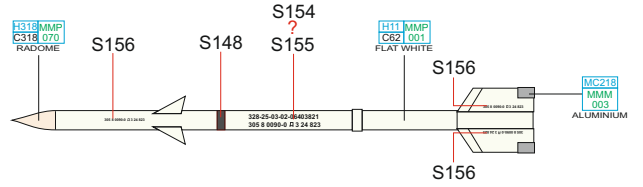
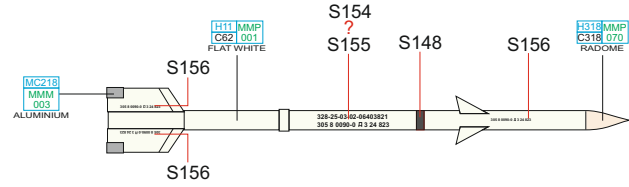

R-13

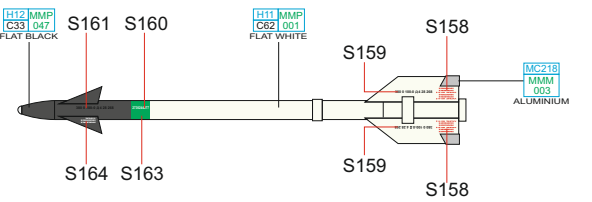
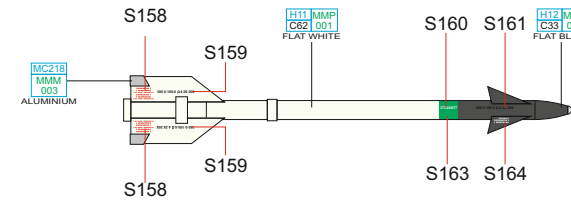

S-24

TOP

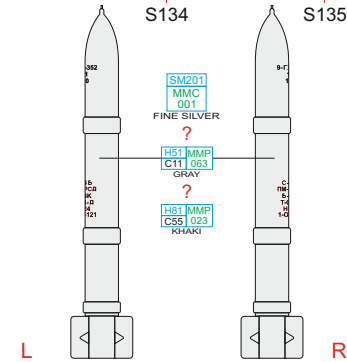
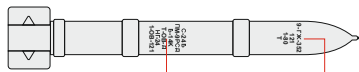

L

R

RS-2US

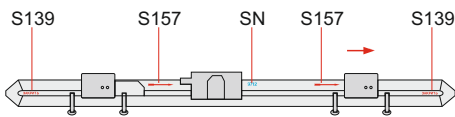
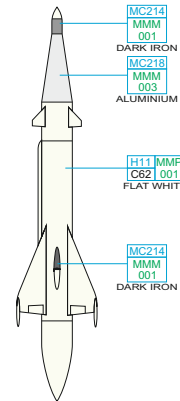

TOP

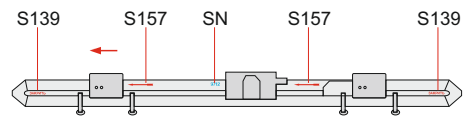

FAB 250

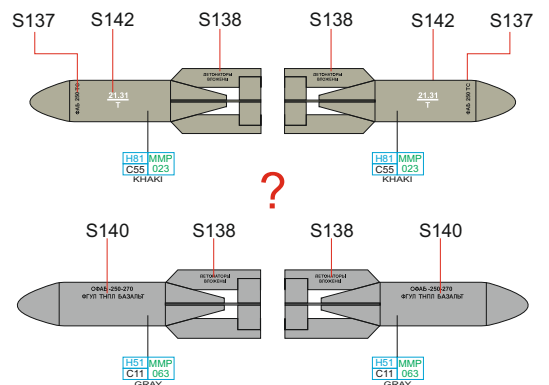

FAB 100

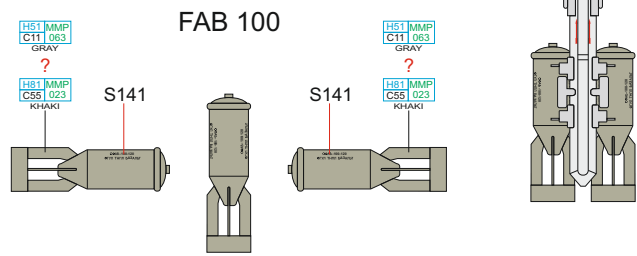

MiG-21MF

STENCILING POSITIONS

Pro letouny kamuflované jsou určeny popisky červené a modré, pro letouny v barvě kovu nebo šedé použijte popisky červené a černé.
 Camouflaged aircraft - red and blue stencils. Natural metal and grey aircraft - red and black stencils.

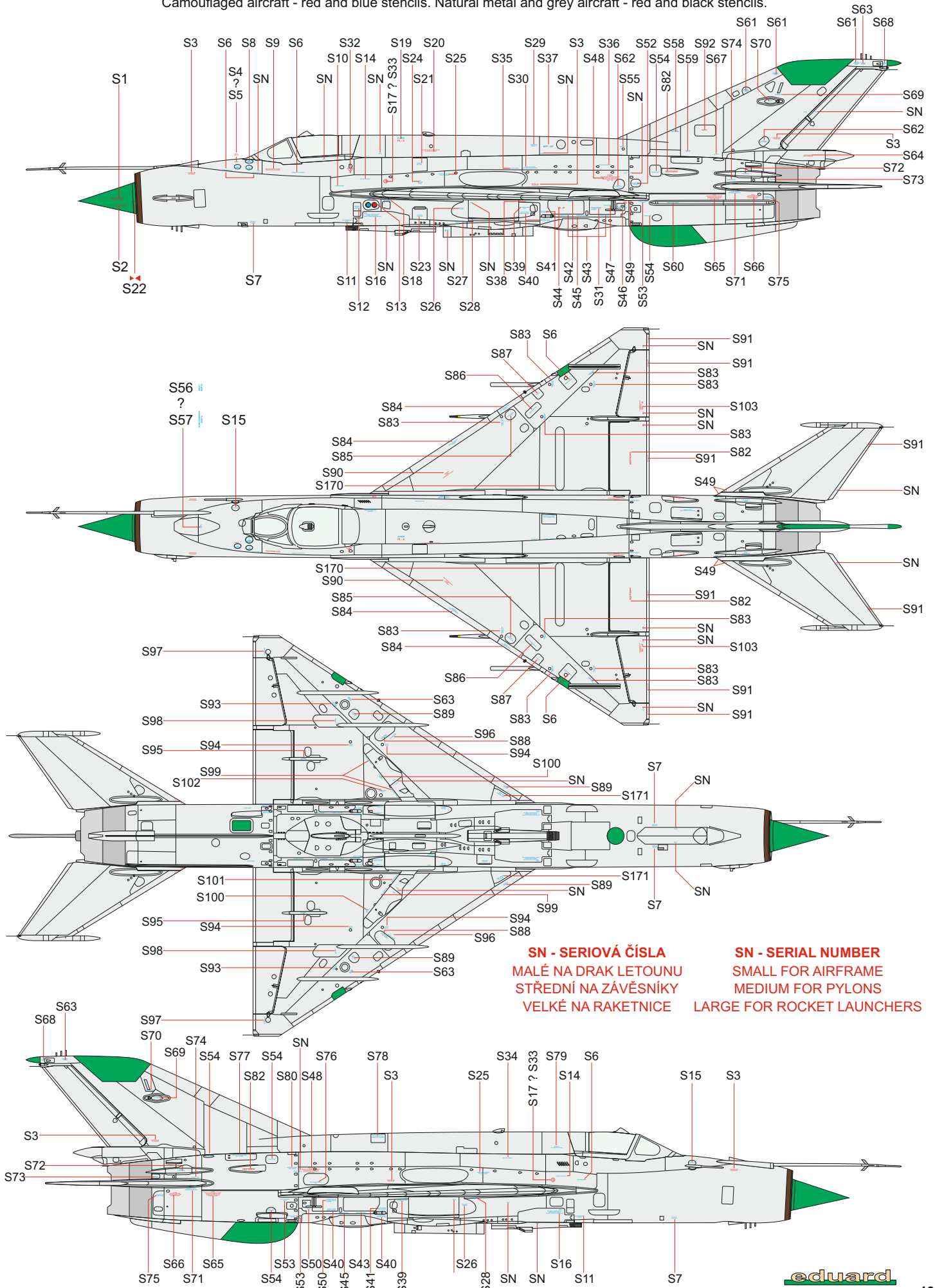

SN - SERIOVÁ ČÍSLA **SN - SERIAL NUMBER**
 MALÉ NA DRÁK LETOUNU SMALL FOR AIRFRAME
 STŘEDNÍ NA ZÁVĚSNÍKY MEDIUM FOR PYLONS
 VELKÉ NA RAKETNICE LARGE FOR ROCKET LAUNCHERS

- 48702 MiG-21MF exterior (PE-Set)
- 48704 MiG-21 ladder (PE-Set)
- FE952 MiG-21MF seatbelts STEEL (PE-Set)
- FE1216 MiG-21MF Weekend (PE-Set)
- 644048 MiG-21MF LööK (Brassin)
- 644055 MiG-21MF early LööK (Brassin)
- 644087 MiG-21MF early LööKplus (Brassin)
- 644088 MiG-21MF LööKplus (Brassin)
- 648025 Rocket launcher UB-16 and UB-32 (Brassin)
- 648026 MiG-21 wheels (Brassin)
- 648030 MiG-21 seat late (Brassin)
- 648036 MiG-21MF interior late (Brassin)
- 648040 RS-2US / AA-1 Alkali (Brassin)
- 648049 MiG-21 wheel wells (Brassin)
- 648064 MiG-21 late airbrakes (Brassin)
- 648080 MiG-21 undercarriage legs BRONZE (Brassin)
- 648125 R-3S / AA-2 Atoll-A (Brassin)
- 648126 OFAB-100 Soviet bombs (Brassin)
- 648127 OFAB-250 Soviet bombs (Brassin)
- 648490 MiG-21 F.O.D. (Brassin)
- 648445 R-13M missiles (Brassin)
- 3DL48034 MiG-21MF SPACE (3D Decal set)
- EX337 MiG-21MF Weekend (Mask)
- EX526 MiG-21MF w/ canopy seal (Mask)
- EX636 MiG-21MF TFace (Mask)



Cat. No. 644048



Cat. No. 648445

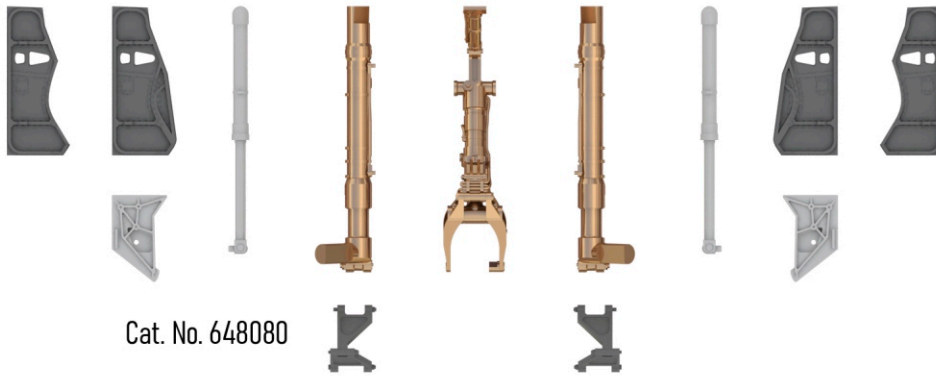
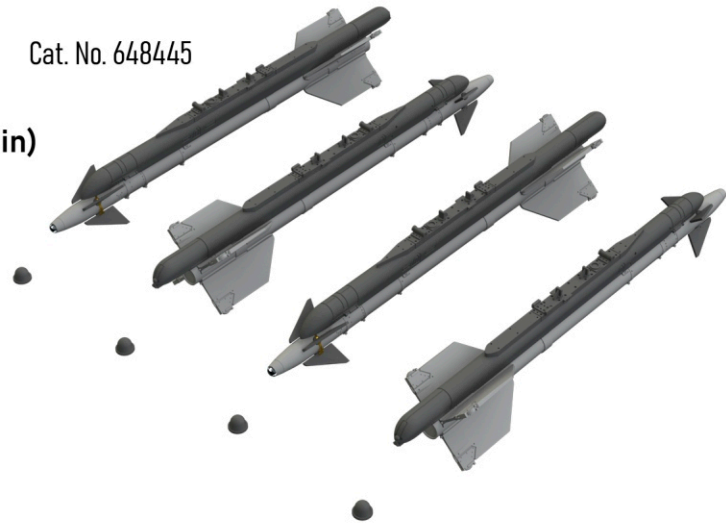

Cat. No. 648080

Cat. No. 648064



Cat. No. 648049

