



MODELLO IN SCALA 1/72  
1/72 SCALE MODEL

# AB41

## Italian Armoured Car



Articolo/Item 72011

### Spa - Ansaldo AB-41

Le prime autoblinde ad entrare in combattimento furono quelle inquadrato nel raggruppamento Esploratori (C.A.M.) in Marmarica.

Esse, poi, furono maggiormente impiegate in Africa Settentrionale, Jugoslavia e Grecia.

In seguito, dopo l'Armistizio, molte unità furono utilizzate dall'Esercito Tedesco

con diverse mimetizzazioni campali (German Armed Forces) e in diverse funzioni secondarie italiane, di polizia, ecc...

Per quell'epoca l'AB 41 e derivati furono considerati mezzi d'avanguardia per diverse caratteristiche tecniche

e combattive: 4 ruote sterzanti, possibilità di guidare nei due sensi di marcia con volante e doppi comandi.

Non ultimo le ruote di scorta laterali agivano anche da ruote folli per superare terreni accidentati difficili.

#### DATI TECNICI:

Peso: 7,4 t

Equipaggio: 3

Velocità massima su strada: 78 km/h

Protezione: 6-18 mm

Motore: 80 hp

Autonomia: 400 km

Armamento: 1 Mitragliera da 20 mm

2 Mitragliatrici da 8 mm

### Spa - Ansaldo AB-41

The first armoured car to enter in combat were those enrolled in the grouping Explorers (C.A.M.) in Marmarica.

Following they were more used in Northern Africa, Yugoslavia and Greece.

Then, after the Armistice, many units were used by German Army with various camouflages

(German Armed Forces) and different functions Italian secondary, example police, etc.

For that period the AB 41 and derivatives were considered means of vanguard technical features and combative:

4 steering wheels, the possibility of driving in both directions of travel with steering wheel and double controls.

Not least the side spare wheels acting also as neutral wheels to overcome difficult uneven ground.

#### TECHNICAL DATA:

Weight: 7,4 t

Crew: 3

Maximum speed road: 78 km/h

Shield: 6-18 mm

Motor: 80 hp

Autonomy: 400 km

Equipped: 1 grape-shot from 20 mm

2 machine-gun from 8 mm

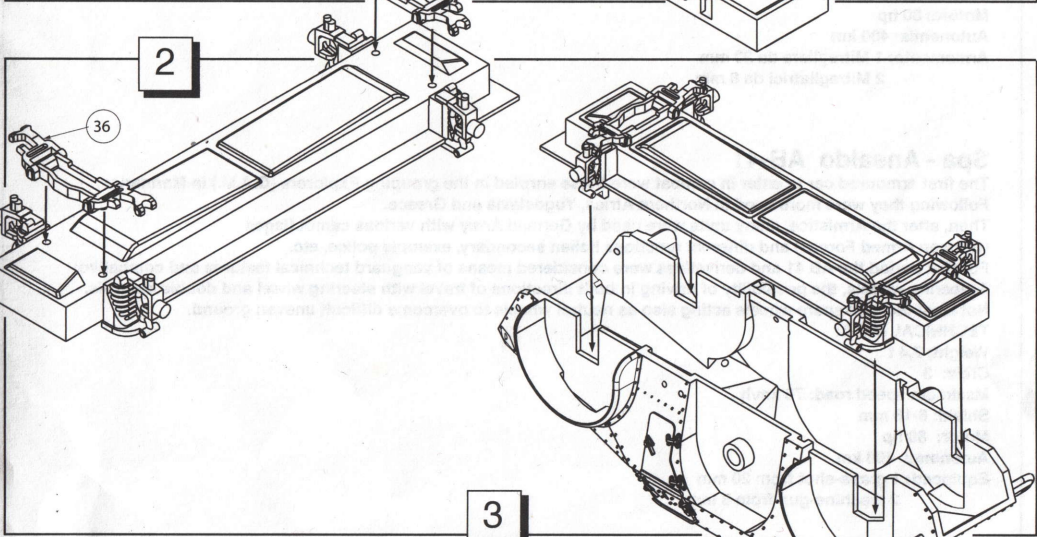
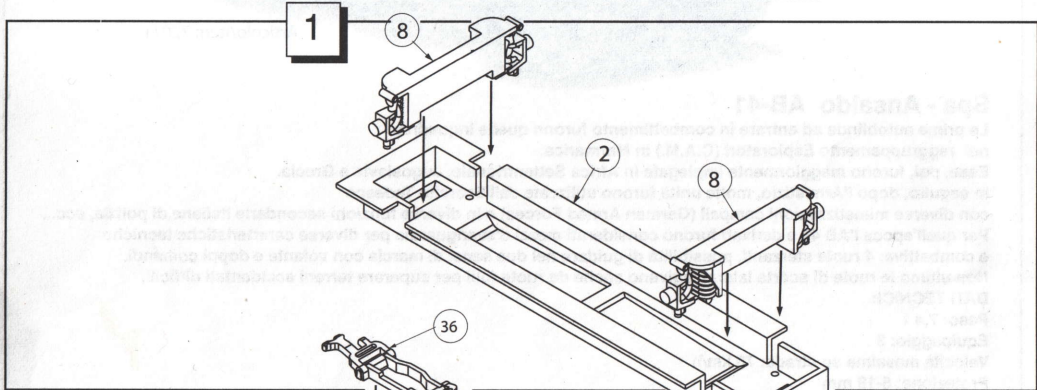
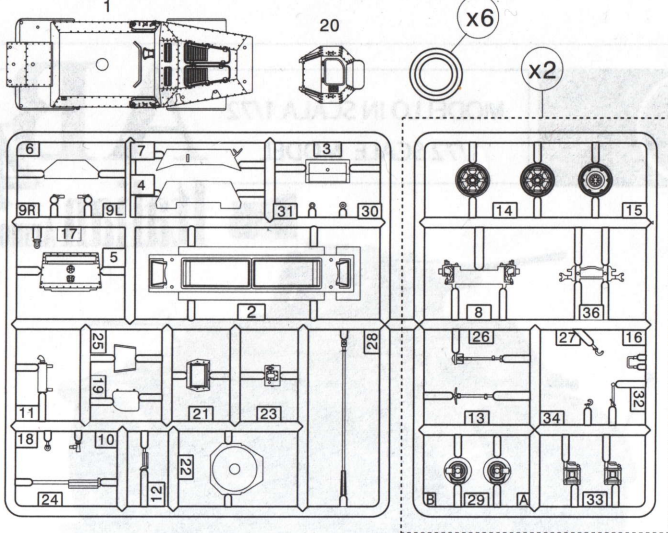

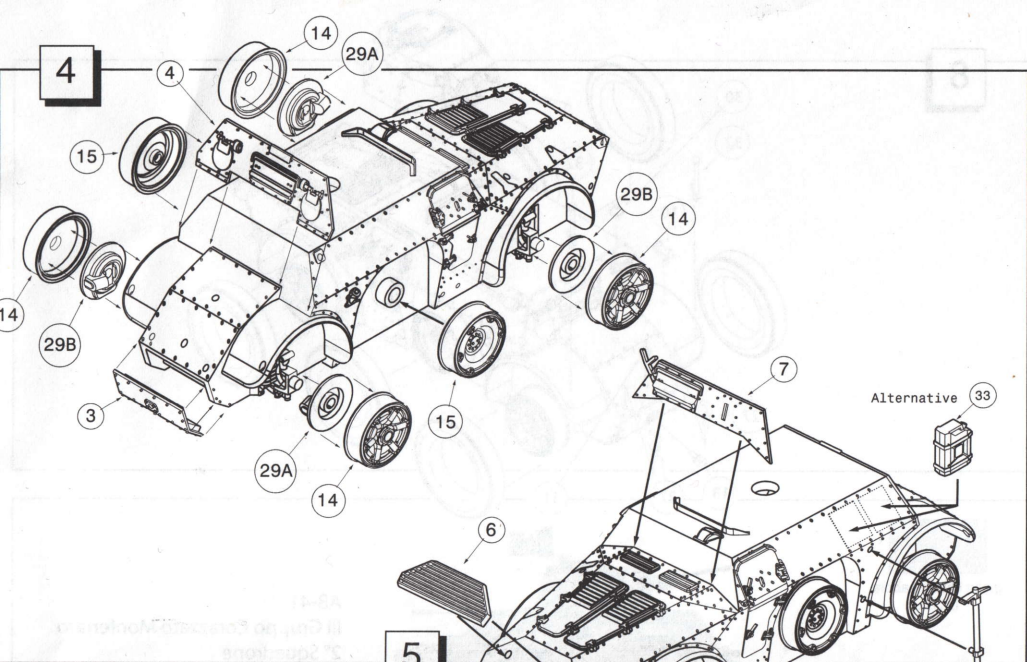
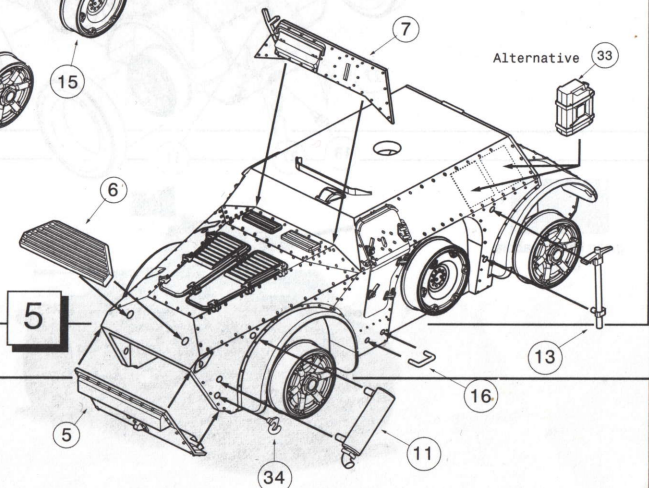
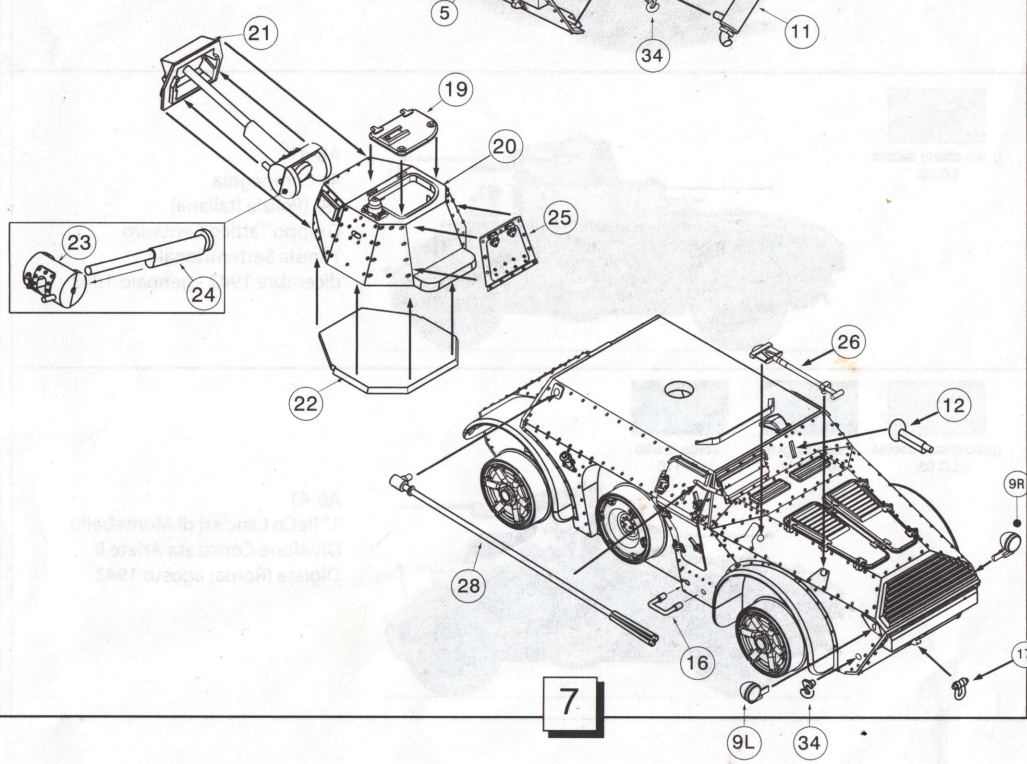
**4****5****6****7**

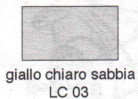
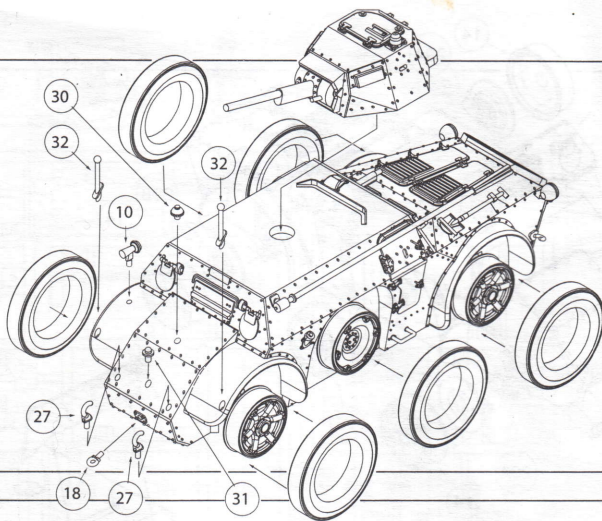

giallo chiaro sabbia  
LC 03

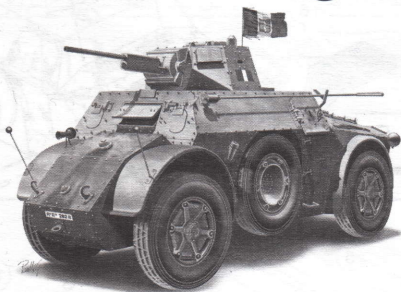

AB-41  
III Gruppo Corazzato Monferrato  
2° Squadrone  
Divisione Corazzata Centauro  
Africa Settentrionale luglio 1942



giallo chiaro sabbia  
LC 03

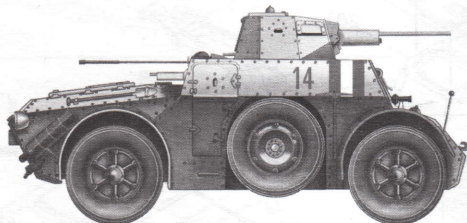

AB-41  
4a Compagnia  
PAI (Polizia Italiana)  
Gruppo Tattico Centauro  
Tunisia Settentrionale  
dicembre 1942 - gennaio 1943



giallo chiaro sabbia  
LC 03



rosso ruggine  
UA 088



verde medio  
UA 110

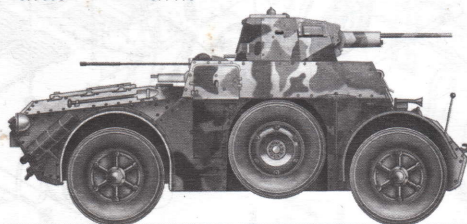

AB-41  
1° ReCo Lancieri di Montebello  
Divisione Corazzata Ariete II  
Olgiata (Roma) agosto 1943

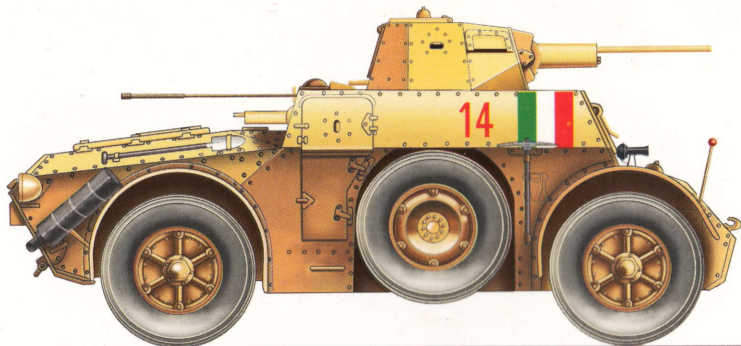

4a Compagnia, PAI (Polizia Africa Italiana), Gruppo Tattico Centauro  
Tunisia dicembre 1942 - gennaio 1943

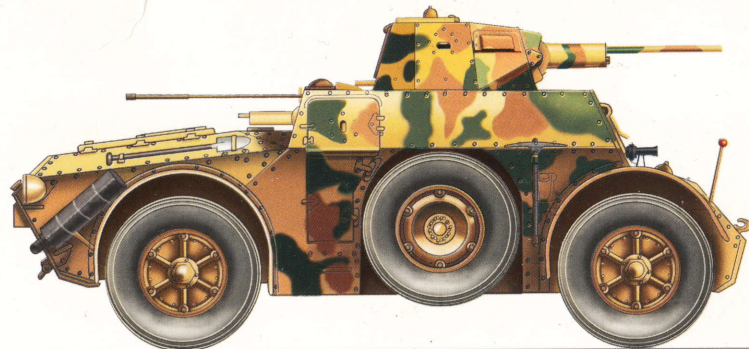

1° ReCo Lancieri di Montebello, Divisione Corazzata Ariete II  
Ogliata (Roma) agosto 1943

### DOC MODELS

AUTOBLINDA AB 41 - SCALA 1/72  
MADE IN ITALY

Le prime autoblinda ad entrare in combattimento furono quelle inquadrare nel raggruppamento Esploratori (C.A.M.) in Marmarica.

Esse, poi, furono maggiormente impiegate in Africa Settentrionale, Jugoslavia e Grecia.

In seguito, dopo l'Armistizio, molte unità furono utilizzate dall'Esercito Tedesco con diverse mimetizzazioni campali (German Armed Forces) e in diverse funzioni secondarie italiane, di polizia, ecc...

Per quell'epoca l'AB 41 e derivati furono considerati mezzi d'avanguardia per diverse caratteristiche tecniche e combattive: 4 ruote sterzanti, possibilità di guidare nei due sensi di marcia con volante e doppi comandi.

Non ultimo le ruote di scorta laterali agivano anche da ruote folli per superare terreni accidentati difficili.

#### DATI TECNICI:

Peso: 7,4 t  
Equipaggio: 3  
Velocità massima su strada: 78 km/h  
Protezione: 6-18 mm  
Motore: 80 hp  
Autonomia: 400 km  
Armamento: 1 Mitragliera da 20 mm  
2 Mitragliatrici da 8 mm

### DOC MODELS

ARMOURD CAR AB 41 - SCALE 1/72  
MADE IN ITALY

The first armoured car to enter in combat were those enrolled in the grouping Explorers (C.A.M.) in Marmarica.

Following they were more used in Northern Africa, Yugoslavia and Greece.

Then, after the Armistice, many units were used by German Army with various camouflages (German Armed Forces) and different functions Italian secondary, example police, etc.

For that period the AB 41 and derivatives were considered means of vanguard technical features and combative: 4 steering wheels, the possibility of driving in both directions of travel with steering wheel and double controls.

Not least the side spare wheels acting also as neutral wheels to overcome difficult uneven ground.

#### TECHNICAL DATA:

Weight: 7,4 t  
Crew: 3  
Maximum speed road: 78 km/h  
Shield: 6-18 mm  
Motor: 80 hp  
Autonomy: 400 km  
Equipped: 1 grape-shot from 20 mm  
2 machine-gun from 8 mm

### CONVERSIONE COLORI - CONVERSION COLORS - KONVERTIERUNG FARBES - COVERSION COULEURS

COLORE	LIFECOLOR	HUMBROL	FS	TAMIYA	TESTOR	GUNZE	RAL
Verde	UA008	149	34092	XF13	1764	H302	6020
Giallo Sabbia	UA080		33434			H34	
Giallo Mim.	UA134	81	33481	XF4	1584	H58	1012
Marrone Mim.	UA088	180	30109	XF64	1785	H33	8004
Terra	UA015	118	30219		1742	H310	