



THE SCALE OF  
THIS MODEL IS  
1/72 ACTUAL SIZE

**Revell**  
Authentic Kits

H-647 ©1966 REVELL INC., VENICE, CALIF. LITHO IN U.S.A.

## PZL P-11c

When the Germans thrust their invasion forces into Poland in 1939, they were met with a totally unexpected opponent, the lively P-11c gull-winged fighter. Although the German Luftwaffe was equipped with the newest combat craft of the day, they did not reckon with the determination and heroism of the Polish Air Force. Though outfitted with the less powerful and somewhat slower P-11c, the skilled and determined Polish pilots took advantage of its remarkable maneuverability and succeeded in destroying over thirty percent of the invading aircraft. In fact, the first German planes destroyed in World War II were downed by P-11's!

The PZL P-11c was so well built that it could withstand a tremendous amount of punishment with no noticeable effect. The plane was of all-metal construction and covered with duralumin sheet, corrugated for added strength. The unique "gull" design of the wing provided exceptional visibility for the pilot. A feature of the P-11, unusual for its time, was the dual use of the ailerons as landing flaps.

P-11's formed the fighting strength of twelve of the fifteen fighter squadrons based in Poland at the time of the German Invasion. Also using the little high-wing monoplane were the Rumanians, who produced P-11's under license in their own factories.

The PZL P-11c could achieve a top speed of 242 mph from its 645 hp, PZL-built Bristol Mercury engine. Service ceiling was 36,000 feet; maximum range was 503 miles. The P-11 measured 35 feet, 2 inches in span and 24 feet, 9½ inches in length.

Your Revell model is a replica of a PZL P-11c armed with four KM WZ.33 7.7 mm machine guns. The sole remaining example of this aircraft is now on display in Warsaw, Poland.

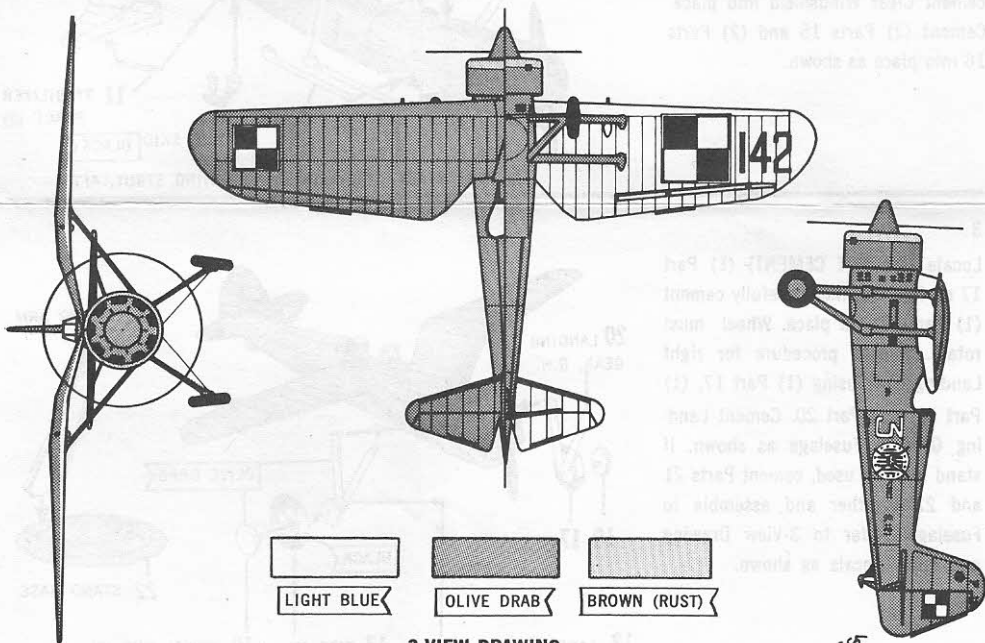

3-VIEW DRAWING

## FOR BEST RESULTS, READ THIS FIRST.

This kit is molded of styrene plastic. REVELL CEMENT & PAINTS are made especially for use with this material. Always fit parts together to be assured of proper assembly before cementing. Before assembling, paint parts as indicated **RED** and allow to dry. Avoid spilling cement or paint, on clothing, or furniture.

1

See Drawing A. Cement Parts 1 and 2 together. Slide (DO NOT CEMENT) Part 3 into place. Locate (DO NOT CEMENT) Part 13 to front of Engine as shown, then carefully cement Part 4 into place. Propeller must rotate. See Drawing B. **NOTE:** If model is to be displayed on stand, trim plastic from stand slots in fuselage halves. Cement Parts 5, 6, 7, and 8 together as shown. Cement Assembly 1A into place on Fuselage Firewall. Align exhaust ports on Part 13 with those on Fuselage, then cement Part 13 into place.

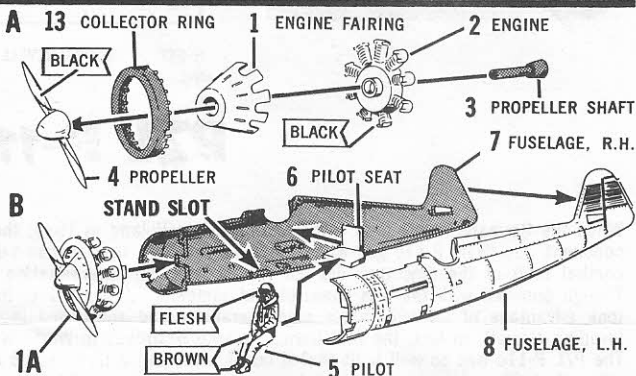

2

Cement Parts 9 and 10 to Fuselage, then cement (2) Parts 11 into place as shown. Cement Part 12 into place. Cement Part 14 to Fuselage, then cement Clear Windshield into place. Cement (2) Parts 15 and (2) Parts 16 into place as shown.

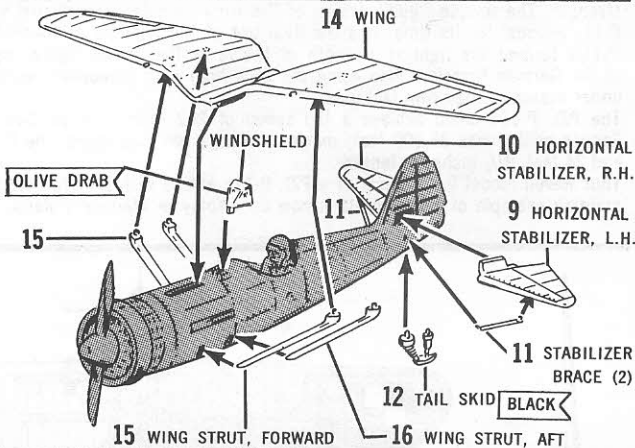

3

Locate (DO NOT CEMENT) (1) Part 17 on Part 18, then carefully cement (1) Part 19 into place. Wheel must rotate. Repeat procedure for right Landing Gear using (1) Part 17, (1) Part 19, and Part 20. Cement Landing Gear to Fuselage as shown. If stand is to be used, cement Parts 21 and 22 together and assemble to Fuselage. Refer to 3-View Drawing and apply decals as shown.

